

HEATSTRIP[®]



Classic (THH-AA) Product Manual



HEATSTRIP[®] Classic with Remote & App
(THH-AA)

www.heatstrip.com.au

Ph: 03 9562 3455 | E: sales@thermofilm.com.au



Specifications - Australia

October 2023 Revision 3

MODEL	POWER (WATTS)	CURRENT (AMPS)	DIMENSIONS (mm)	WEIGHT (Kg)	LEAD LENGTH (mm)	PLUG
THH2400AA	2400	10	1364 x 165 x 48	7	1000	YES
THH3200AA	3200	13.3	1774 x 165 x 48	9	500	NO

MODEL							
HEATER TYPE	High intensity electric radiant overhead heater with high surface area profiled alloy						
OUTPUT	Refer to model code chart above						
POWER	230-240 Volts Nominal at 50—60 Hertz, Single Phase						
CONNECTION	3 Core Cable 2.5mm ²						
APPROVALS	AUSTRALIA/NZ						
MOUNTING HEIGHT	<table border="0"> <tr> <td>MINIMUM</td> <td>2.1 m</td> </tr> <tr> <td>RECOMMENDED</td> <td>2.3 m to 2.5 m</td> </tr> <tr> <td>MAXIMUM</td> <td>2.7 m in a fully enclosed outdoor area (For higher ceiling heights, units can be lowered using optional bracket kits or refer to the Heatstrip Max range)</td> </tr> </table>	MINIMUM	2.1 m	RECOMMENDED	2.3 m to 2.5 m	MAXIMUM	2.7 m in a fully enclosed outdoor area (For higher ceiling heights, units can be lowered using optional bracket kits or refer to the Heatstrip Max range)
MINIMUM	2.1 m						
RECOMMENDED	2.3 m to 2.5 m						
MAXIMUM	2.7 m in a fully enclosed outdoor area (For higher ceiling heights, units can be lowered using optional bracket kits or refer to the Heatstrip Max range)						
MOUNTING OPTIONS	Suitable for ceiling, wall, beam, fixed umbrella and recess mounting. Also available for extension mount using rigid fixing poles and chain mount bracket.						
PROTECTION RATING	IP55 Protection from water ingress from all directions						
COUNTRY OF MANUFACTURE	Australia						

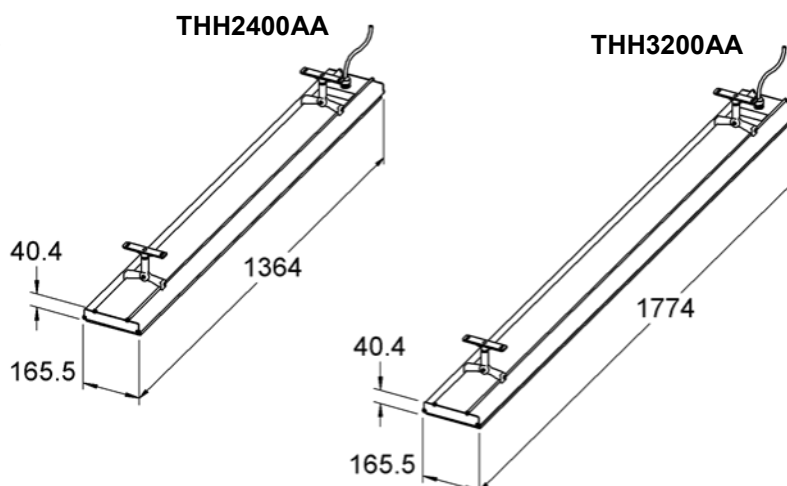



Operating cost comparison

In many instances, patio heaters powered by gas bottles are used as an outdoor heating source. The below table shows the operational cost comparison between HEATSTRIP® and a bottled gas outdoor heater. Not only are the hourly running costs considerably less with HEATSTRIP®, but you never have to worry about running out of gas, no refilling, no unattractive gas bottle to waste space; and HEATSTRIP® actually improves the value of your property.

RUNNING COST	OUTDOOR GAS HEATER	HEATSTRIP® CLASSIC WITH REMOTE & APP ELECTRIC RADIANT HEATER	
		THH2400AA	THH3200AA
PER HOUR	\$2.78/hr	\$0.48/hr	\$0.64/hr
PER YEAR	\$500.40	\$86.40	\$115.20

Notes:

1. Calculations of hourly running cost for outdoor gas heater is based on \$25.00 average to fill a 9kg gas bottle and average running time of 9 hours. $\$25.00 / 9 \text{ hours} = \2.78 per hour
2. Electricity rate of 20.0 cents/kWh
3. All calculations are excluding GST.
 - 1.8kW x 0.20 cents = \$0.36 or 36 cents per hour
 - 2.4kW x 0.20 cents = \$0.48 or 48 cents per hour
 - 3.2kW x 0.20 cents = \$0.64 or 64 cents per hour

Calculations of yearly running cost are based on 180 hours usage
 180 hours x \$2.78 = \$500.40 yearly running cost for outdoor gas heater
 180 hours x \$0.48 = \$86.40 yearly running cost for 2400W HEATSTRIP®
 180 hours x \$0.64 cents = \$115.20 yearly running cost for 3200W HEATSTRIP®





Spot heating principle

In most outdoor or difficult-to-heat indoor applications, there are 2 options when looking at the size and quantity of the heaters required.

Option 1 is to comfort heat the entire area based on the total dimensions of the space, regardless of whether the entire area is being fully occupied.

Option 2 is to spot heat the high use areas, such as over outdoor tables, BBQ's, lounges, assembly lines or indoor workstations.

Often it is more practical and efficient to spot heat high use areas. Spot heating will reduce both the initial capital cost as well as the ongoing running costs. Spot heating will allow the area to be "zoned", meaning only the areas that are being used are heated, such as tables in a restaurant or outdoor alfresco area.

Option 1 and 2 show a comparison between heating an entire area or spot heating over a table.

The bottom layout shows the flexibility of using HEATSTRIP® to provide a comfortable environment, even when the layout of the area is very unusual.

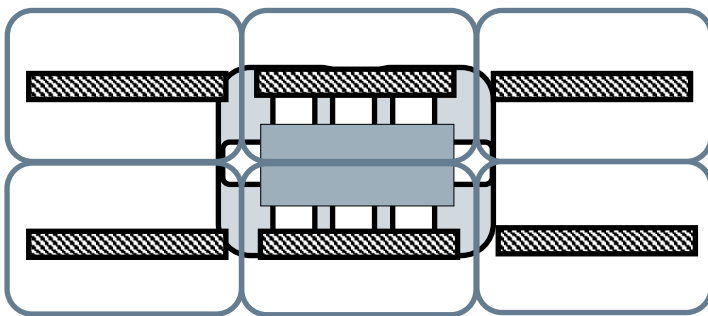

Option 1: 6 x THH2400AA

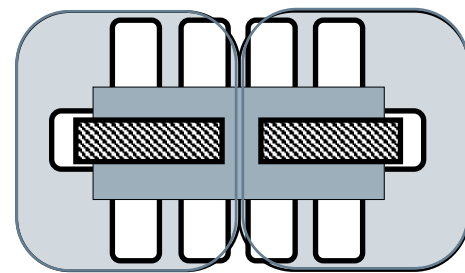

Option 2: 2 x THH2400AA

Proposed Outdoor Area layout

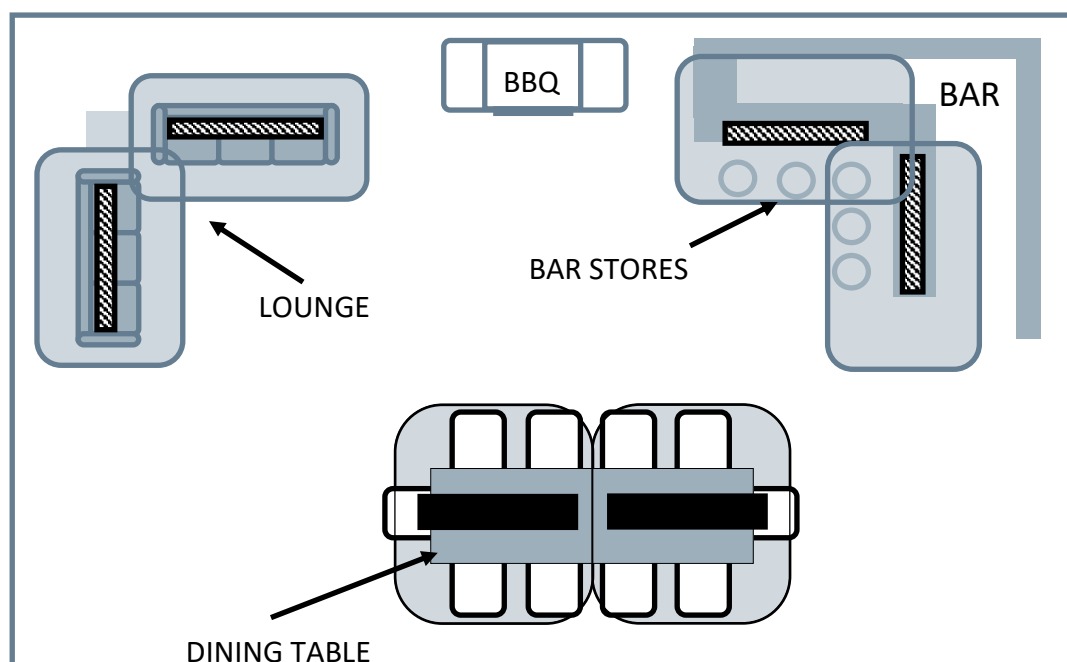

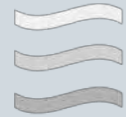

Radiant footprint

HEATSTRIP® electric heaters produce radiant heat which heats objects rather than the air. Therefore, it is imperative that objects to be heated (ie. people), are within the direct radiant footprint of the heater.

The diagram to the left shows the radiant footprint of HEATSTRIP® Classic with Remote and App, and is an approximate guide based on a fully enclosed outdoor environment.

This diagram shows that the maximum heat output is found directly under the heater, and the temperature decreases as you move away from the heater.

It highlights the importance of maintaining recommended mounting heights, and if possible, positioning the heater directly above the area to be heated.

Note that the temperature is the same for all 4 models, regardless of the wattage. However, as the size increases and the length of the unit increases, the radiant footprint will be longer.

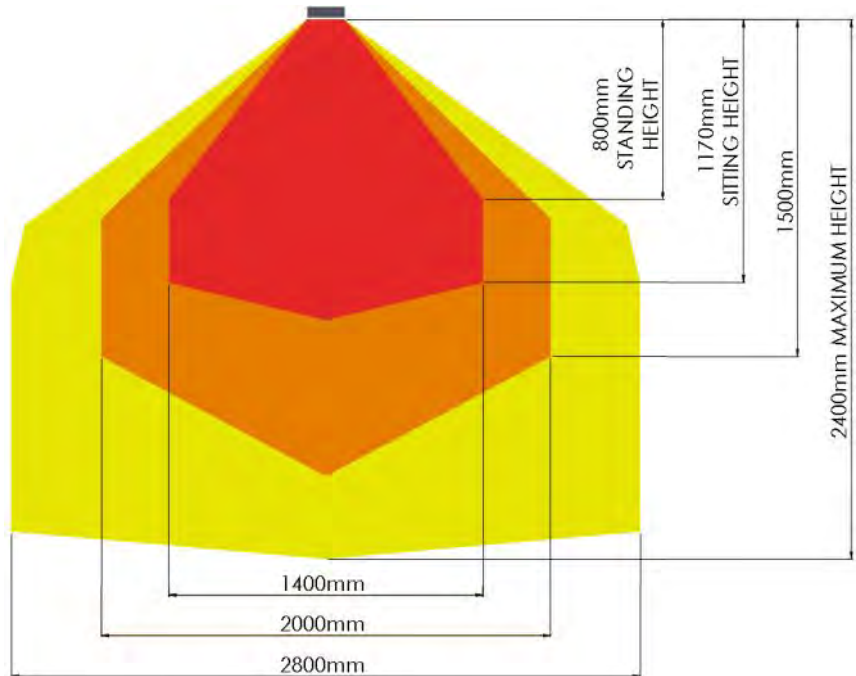

The below diagrams show the approximate heating area for each model, based on both an indoor and outdoor enclosed environment, with direct overhead mounting.

The radiant footprint is reduced in angled, wall mounted installations.

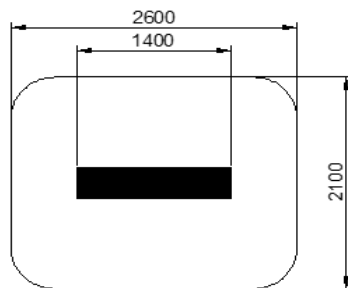

THH2400AA

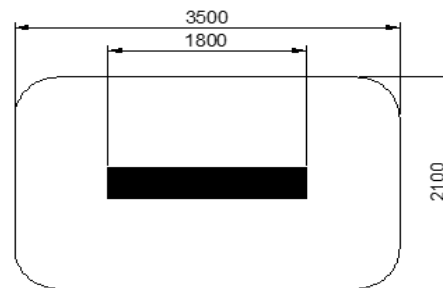

THH3200AA

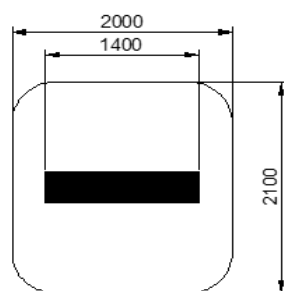

THH2400AA

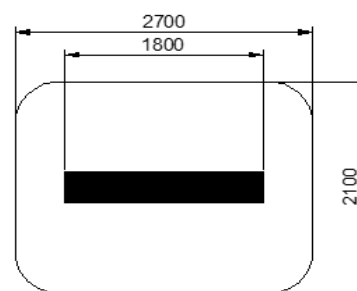

THH3200AA



Selection guide

General recommendations for **HEATSTRIP® Classic with Remote and App control**:

- Ideal mounting height: 2.3m to 2.5m. Maximum is 2.7m in a fully protected/enclosed outdoor environment.
- Ideal mounting location: ceiling mounted, directly above area to be heated (eg. above a table)
- Based on the radiant footprint of the previous page, for a protected outdoor area, a minimum of 500W/m² is required. For indoor spot heating, a minimum heating capacity of 400W/m² is recommended.

The table below outlines the coverage of each **HEATSTRIP® Classic with Remote and App control** model based on 3 different scenarios with direct overhead mounting. For example, for an outdoor area that is protected from prevailing winds by walls, café blinds etc, Model THH2400AA will cover 4.8m². Model THH3200AA will cover 6.4m². For angled wall mounting applications, the coverage is reduced by up to 40%.

MODEL	INDOOR PROTECTED (m ²)	OUTDOOR ENCLOSED (m ²)	OUTDOOR EXPOSED (m ²)
THH 2400A	6	4.8	4
THH 3200A	8	6.4	5.3

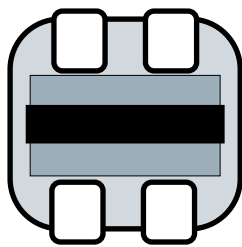



Table layout

For the majority of outdoor applications, the most effective method is to spot heat a table or similar area. The diagrams below provide an easy selection guide for the approximate model and quantity of heaters required to heat common residential table settings.

Selections are based on HEATSTRIP® Classic with Remote and App being mounted at 2.4m from the floor in a fully enclosed undercover outdoor area.



1 x THH2400AA

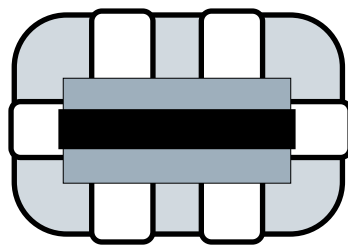

1 x THH3200AA

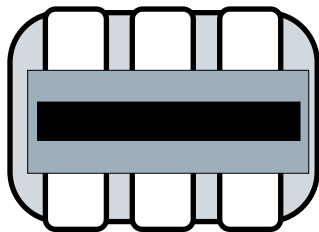

1 x THH3200AA

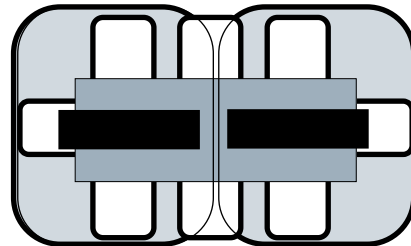

2 x THH2400AA

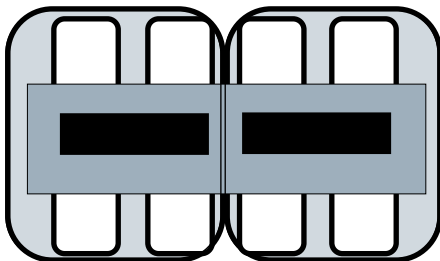

2 x THH2400AA

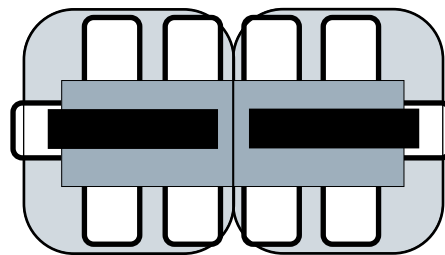

2 x THH2400AA

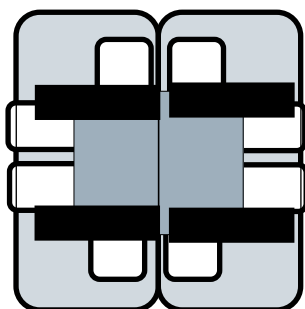

4 x THH2400AA

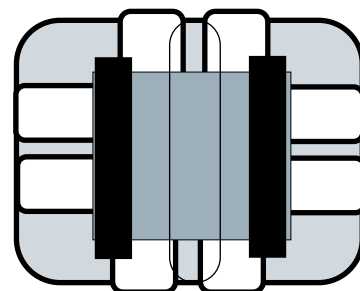

2 x THH3200AA





Installation Requirements

The ideal mounting position for the HEATSTRIP[®] Classic with Remote and App is on the ceiling directly above the area to be heated. If this is not possible, HEATSTRIP[®] can be mounted on a wall and angled downwards. In this situation, ensure the mounting height is in the range of 2.1m to 2.7m and the table is within 2.5m of the wall.

For mounting heights more than 2.7m, we recommend the use of the optional accessories to reduce the height of the heater to 2.3m—2.5 m. This will increase the effectiveness of your HEATSTRIP[®]. Refer to the Mounting Accessory section for more information.

Electrical connections/GPO's should not be located at the back of the heater. They should be located outside the physical footprint of the units to minimize heat build-up behind the units.

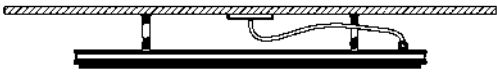
If the heater is to be mounted on an incline (e.g. vaulted ceiling), ensure the electrical connection is located at the lowest point of the heater.

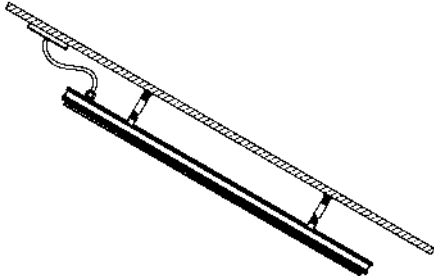
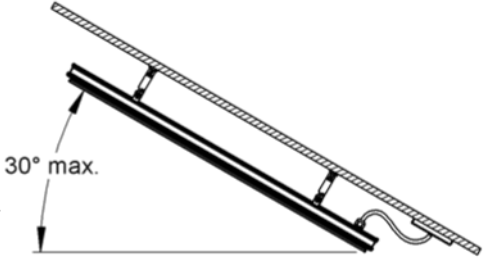
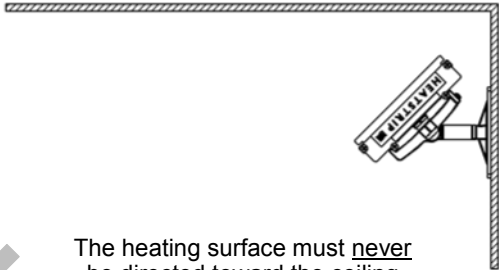
Incorrect Installation	Correct Installation
	
	
 <p data-bbox="309 1912 651 1966">The heating surface must <u>never</u> be directed toward the ceiling</p>	

HEATSTRIP®

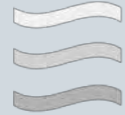

Installation location — the diagrams below provide the minimum recommended clearances in mm.

WARNING: This heater is not equipped with a device to control the room temperature. Do not use this heater in small rooms when they are occupied by persons not capable of leaving the room on their own, unless constant supervision is provided.

Angled Wall Installation

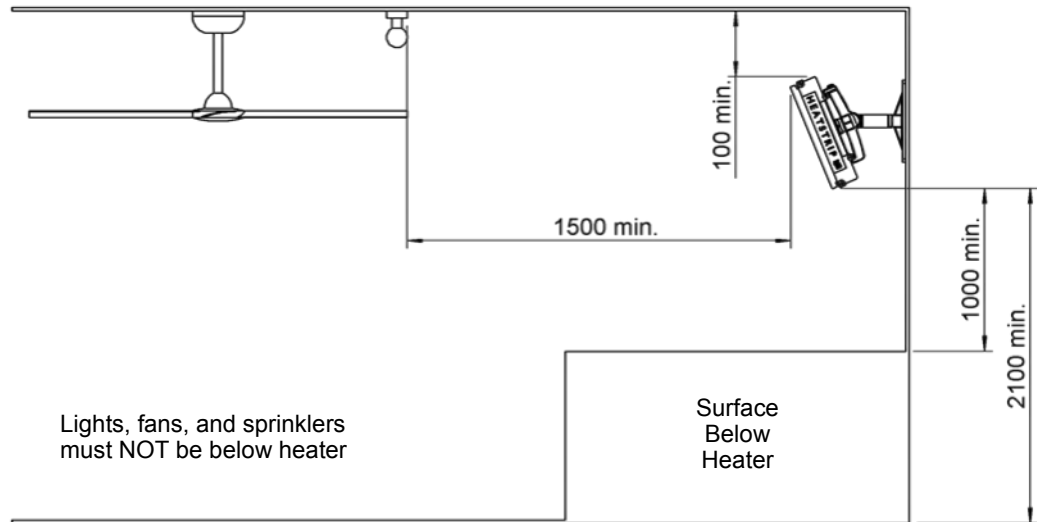

Ceiling Installation

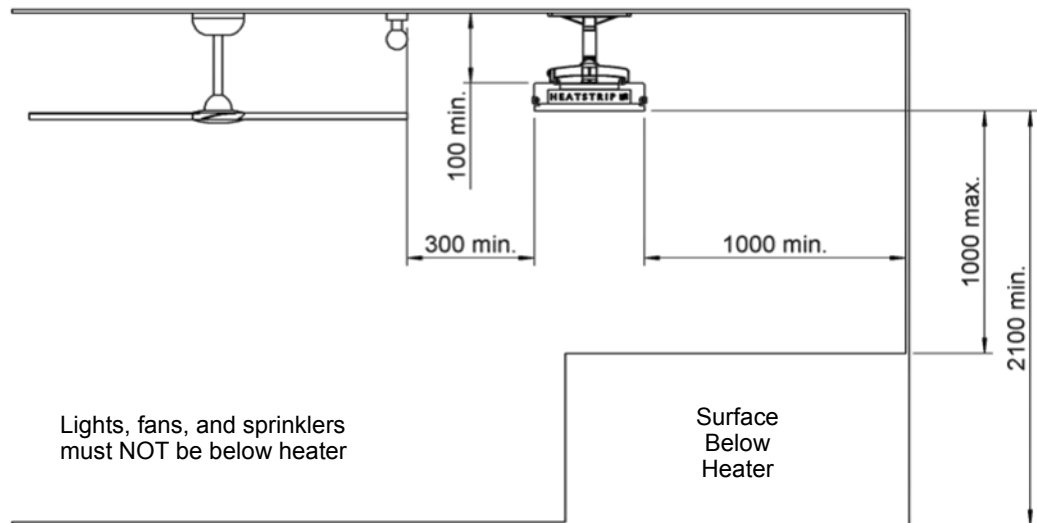

Angled Ceiling Installation

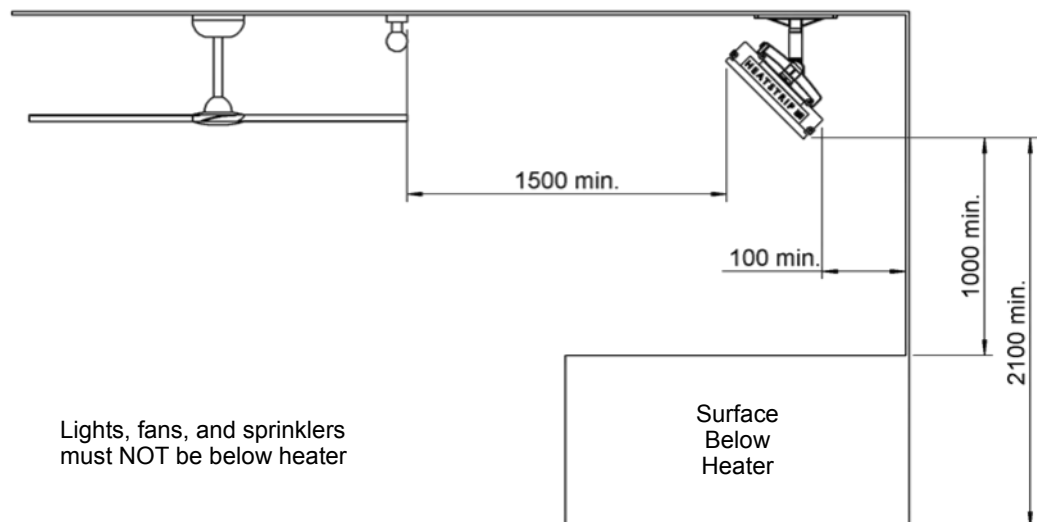



Mounting options

Installing the HEATSTRIP® Classic (with remote & app control) is simple and easy using the standard mounting brackets supplied. For other irregular locations there are range of mounting options available - refer to diagrams below

The HEATSTRIP® Classic (with remote & app control) can be mounted directly to the ceiling, angled downwards on a wall, fitted flush with the ceiling, suspended on chains or poles, attached to beams or poles, mounted end-to-end, or 2 units side-by-side together. Refer to the following pages for more detailed information on each mounting option.

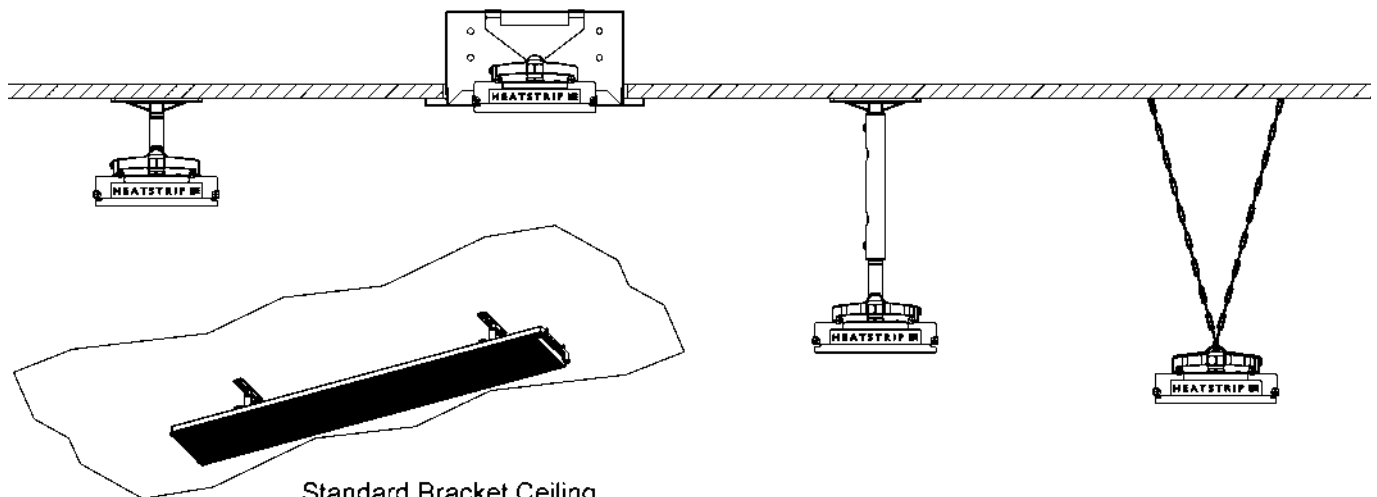

Standard Bracket Ceiling

Flush Mount Enclosure

Extension Mounting Bracket

Chain / Wire Mounting

HEATSTRIP®



Standard mounting brackets

The HEATSTRIP® Classic (with remote & app) comes with a pair of standard mounting brackets. These adjustable brackets allow direct ceiling or wall mount, and come with preset angle options of parallel, 22.5° and 45°.

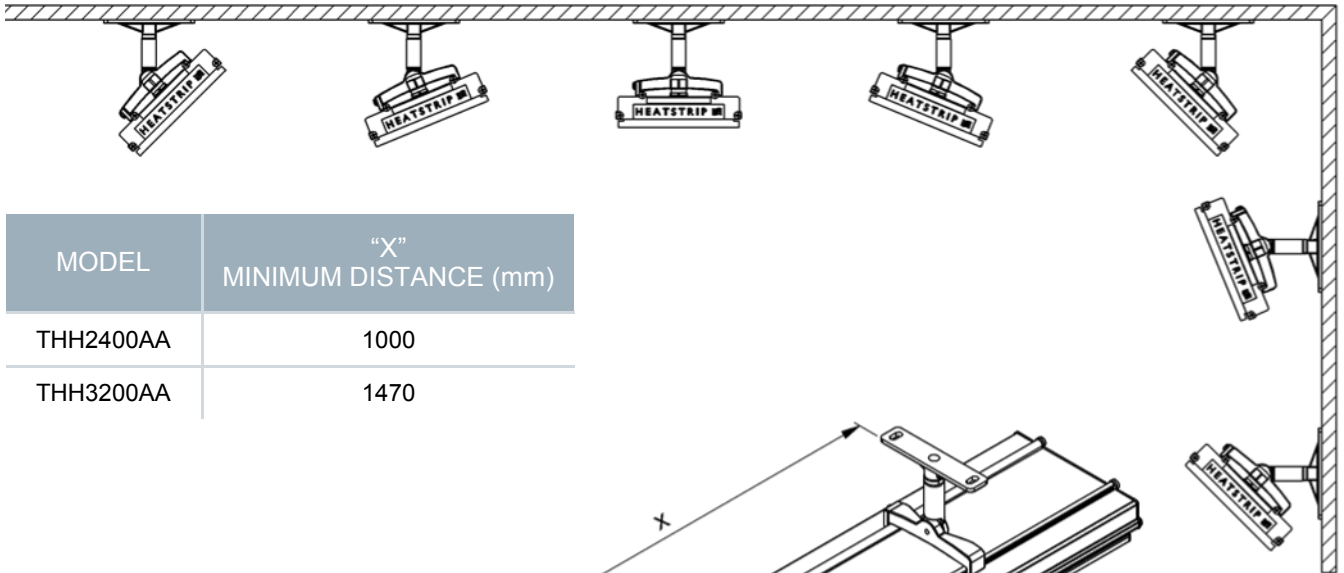

MODEL	"X" MINIMUM DISTANCE (mm)
THH2400AA	1000
THH3200AA	1470

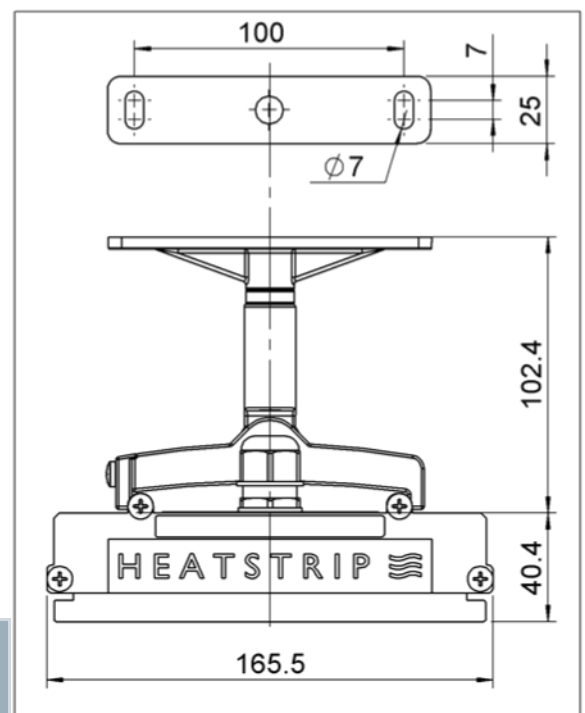
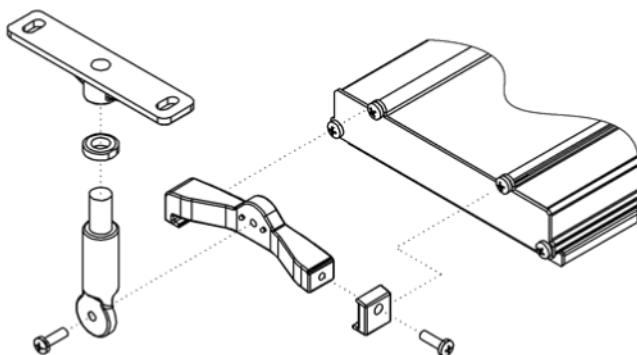

PART No	PACKAGED DIMENSIONS (mm)	WEIGHT (kg)	MATERIAL	COLOUR
ZBRAK-113B	125 x 150 x 40	0.2	ANODISED	BLACK



Flush mount enclosure

The Flush Mount Enclosure is an ideal way to neatly install the HEATSTRIP® into a ceiling. They are available for all HEATSTRIP® Classic models, and are supplied as a one-piece unit suitable for mounting individual heaters. Flush mounting can be used with plaster or timber lined ceiling materials.

An ideal mounting height is 2.3m-2.5m, with a maximum ceiling height of 2.7m in an outdoor enclosed environment. Maximum mounting heights should be strictly followed, otherwise the performance of the units may be reduced.

The fascia of the enclosure is manufactured from 316 Stainless Steel and the rear casing is black zinc coated steel.

Please refer to the Flush Mount Enclosure Installation Manual for more detailed installation information.

SUITABLE FOR MODEL	PART No	HOLE CUTOUT DIMENSIONS (mm)	OVERALL DIMENSIONS (mm)	WEIGHT (kg)
THH2400AR & THH2400AA	THHAC-013	222 W x 1468 L	280 W x 1526 L x 125 D	8
THH3200AR & THH3200AA	THHAC-014	222 W x 1878 L	280 W x 1936 L x 125 D	9

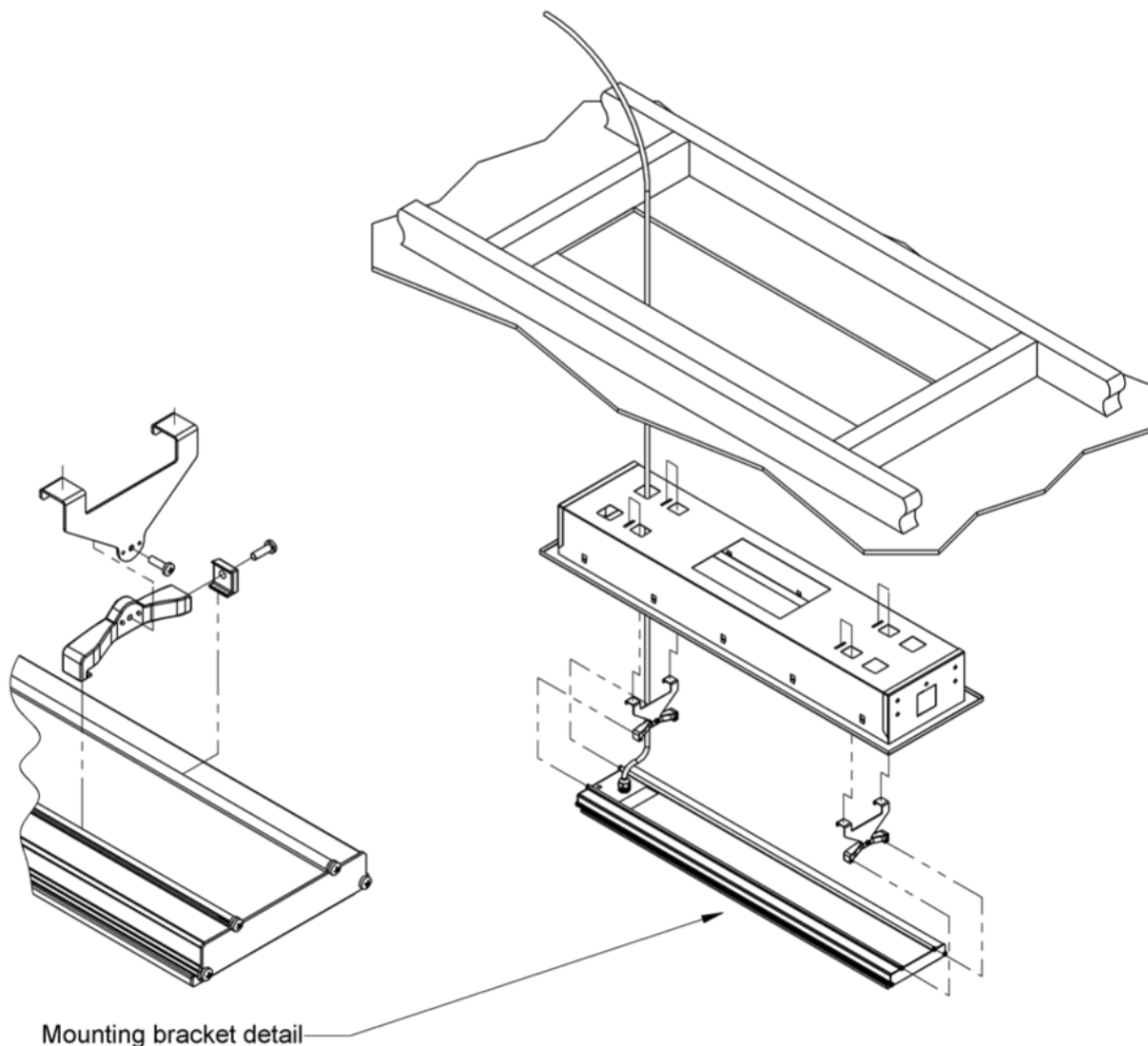



HEATSTRIP Wall Mounting Kit - (THHAC-028)

HEATSTRIP Wall Mounting Kit is an ideal way to install units into hard to mount applications where wall mounting is preferable to direct overhead mounting, applications include heating over tables, lounges, work stations etc. These kits are suitable for all HEATSTRIP Elegance & Classic models.

Instructions:

Fix the wall bracket in the desired location using 6 x 8 mm fasteners that will be more than adequate to safely support the bracket and the HEATSTRIP unit.

When bracket is installed lift the heater into position passing the power cord through the hole. Locate the heater so the L bracket fits into the mounting groove located on the back of the HEATSTRIP. Position the angle piece into the mounting groove on opposite side of the heater and secure firmly onto the bracket using the 3 screws provided.

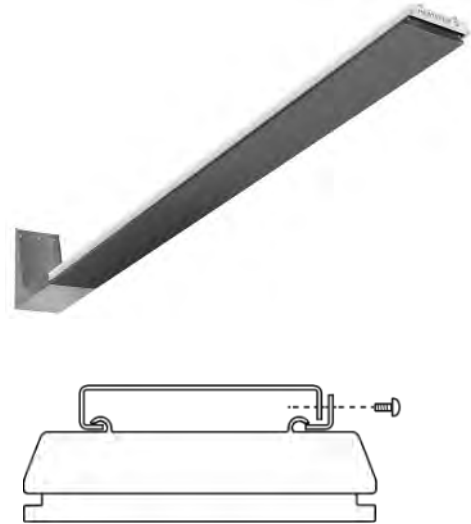

Installation Location

The below diagram outlines the recommended clearances.

Note: The minimum height from the ground to bottom of the bracket is 2.1m, and the maximum height from the ground to the end of the heater is 2.7m. We recommend a mounting height of 2.3 to 2.5m.

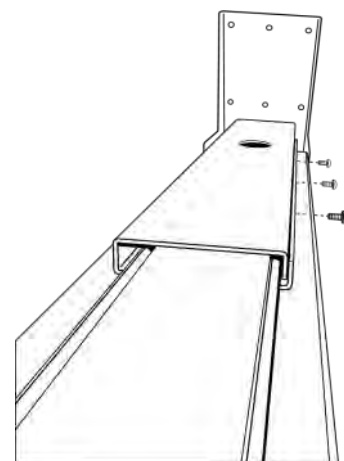
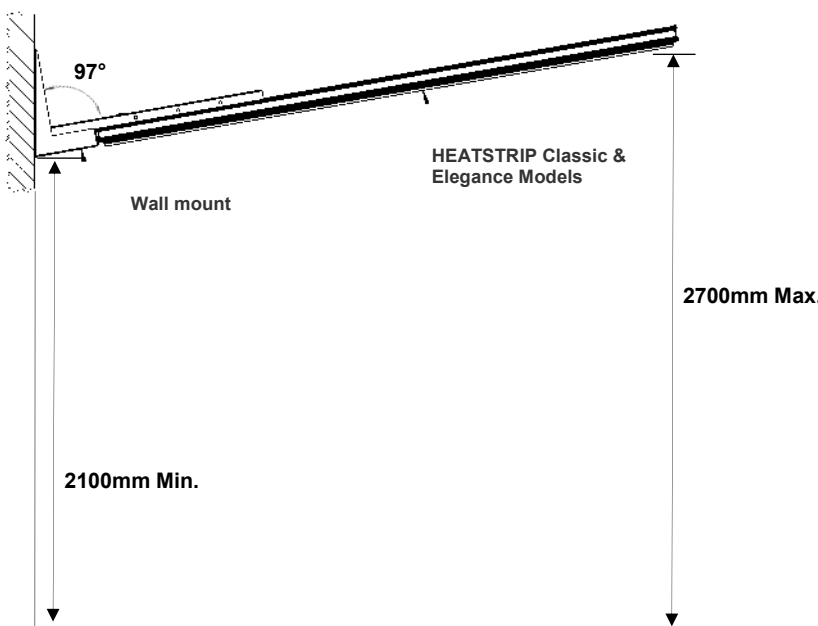

FLOOR

DIMENSION (mm)	WEIGHT (Kg)	MATERIALS
550 (L) x 165 (W) x 250 (H)	3.5	Powder coated Mild Steel



Extension Mount Bracket

The Extension Mount bracket allows HEATSTRIP® Classic units to be lowered from high ceilings using rigid connections. The brackets are designed to be used with 20mm x 20mm x 1mm tube (SHS), and can be supplied as brackets only for customising the length of the drop on site, or supplied as a complete kit with brackets, pre-cut poles and connections. The standard length options as part of the kit are 150mm, 300mm, 600mm, 900mm and 1200mm.

The extension mount brackets utilise components from the standard bracket kit which is supplied with each heater.

*screws to ceiling are not included

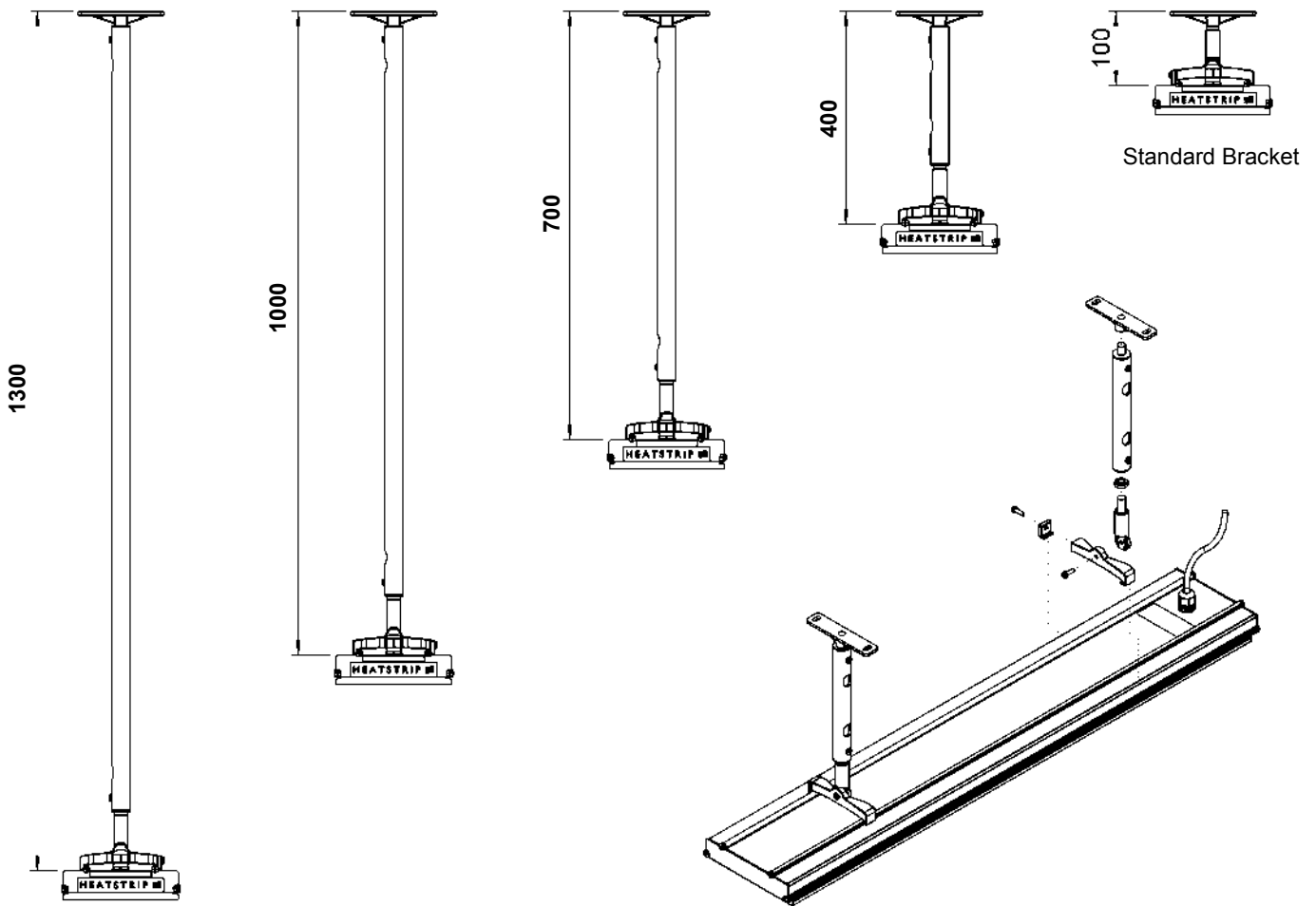

PART No	DIMENSIONS (mm)	WEIGHT (kg)	MATERIALS	NOTES
THHAC-005	300 x 20 x 20	0.21	ALLOY	Kit Includes 2 x 300mm Extension Poles
THHAC-006	600 x 20 x 20	0.38	ALLOY	Kit Includes 2 x 600mm Extension Poles
THHAC-007	900 x 20 x 20	0.55	ALLOY	Kit Includes 2 x 900mm Extension Pole
THHAC-008	1200 x 20 x 20	0.71	ALLOY	Kit Includes 2 x 1200mm Extension Pole



Remote Control Operation

When the heater is plugged in or hardwired, press “power” on the remote, the power indicator light on the unit will light up and indicate the L1, L2, L3 using the + or - to change the heat settings, To set the timer click the time button.

Remote functions:

The heater temperature control L1 is the lowest heat setting and L3 is the highest heat setting.

The timer function has 0-24 hour timer. This feature is ideal for applications such as alfresco areas, restaurant dining, assembly line production etc. when continuous heat is not required. The timer also reduces the likelihood of heaters being inadvertently left turned on.

Remote pairing

All units operate using the same remote control frequency, therefore, multiple heaters can be operated using a single remote control. The remote will function at distance of over 8m when used in a straight line. This distance reduces when used at an angle.

Signal Transmitter

- To use the remote controller, aim the transmitter to the heater. A line of sight transmission is required for the unit to function.
- The controller does not have a protection rating. The controller must be kept away from wet applications.
- The remote will function at distances of over 8m when used in a straight line. This distance reduces when used at an angle.

On/Off Button

- Press this button once to turn on/off operation



Timer

- Timer function 0-24 hour timer, press through to set timer.

Temperature Control Button

- Temperature is adjustable from L1-L2-L3
- The temperature ranges from high to low.

Battery

- 2 x AAA Batteries required for operation.

Remote battery	2x AAA batteries
Remote range	2m—8m
Wall socket supply	220V — 240V, 50Hz
Max load	10A (2400W) 15.5A (3600)
Standby consumption	<1W
Remote frequency	38kHz IR

HEATSTRIP[®]



THH-AA Setup Instructions

1

Visit the Apple App store or Google Play and download TuyaSmart App

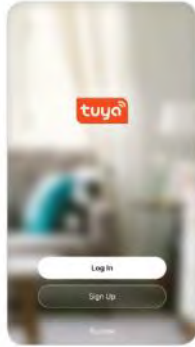

2

Register and login into TuyaSmart App. (Make sure Wi-Fi is enabled)

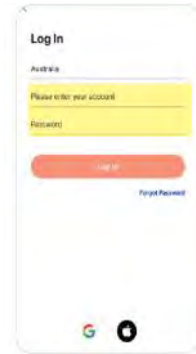

3

Connect the HEATSTRIP Heater to Power. (Either Plug-In or Hardwired)

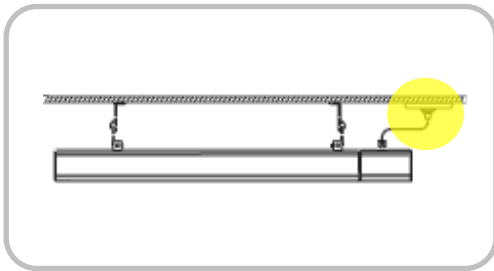

4

Once the power is switched on, hold the + button on the remote until the LED screen is blinking CC.



5

Open the App and select "Add Device"

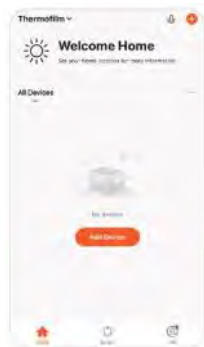

6

Select Device Type "Small Appliances".



7

Select "Heater"



8

Select "Next" (Wi-Fi must be connected).

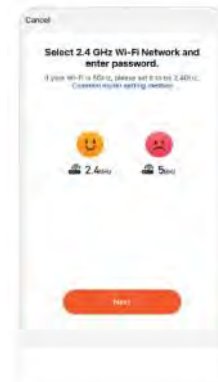

HEATSTRIP[®]



THH-AA Setup Instructions

9

Confirm the 3 indicator is blinking rapidly on the heater and select “Next” (If the LED lights are not blinking on the heater, you will need to hold down the 2H button on the remote until the 3 indicators are blinking).



10

Once the pairing cycle has been completed, the App and HEATSTRIP Heater should be paired together.

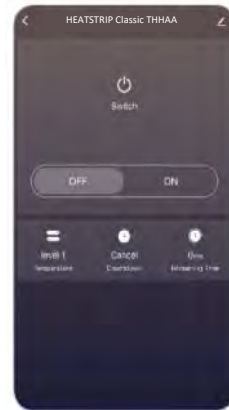

Pairing with Google Assistant

1. Download the Google Home app on the app store or Google play
2. Pair the Google device to the Google Home App
3. Once paired, click on the Tuya Smart App
4. Select “Me”
5. Select “Google Assistant”
6. Select “Link with Google Assistant”
7. Select “Agree and link”
8. Choose device “Select HEATSTRIP Classic with Remote & App
9. Pairing completed



Safety

HEATSTRIP[®] Classic with Remote and App has an IP rating of 55. This means it is safe for water ingress from all directions. The HEATSTRIP[®] can be safely hosed down.

HEATSTRIP[®] has undergone extensive testing both in laboratory conditions, in Thermofilm's manufacturing facility in Melbourne and field trials in Australia and overseas. It is this testing that gives the purchaser the confidence of a high quality product.

Independent laboratory testing has confirmed Thermofilm's full compliance with Australian and other International Standards including CE, AS/ANZ, UL/CSA

The heater comes in both plug (1500W, 1800W, 2400W) and hardwired (3200W) versions. In both cases the fixed wiring must be installed by a licensed electrician in accordance with the relevant wiring regulations.

HEATSTRIP[®] is Class 1 equipment and must be earthed.

In operation, this heater is VERY HOT— do not touch any part of the heater while it is turned on. Do not touch any part until 30 minutes after it is turned off.

This appliance is not intended for use by persons (including children) with reduced physical, sensory or intellectual capabilities, or lack of experience and knowledge, unless they have been given supervision or instruction concerning use of the appliance by a person responsible for their safety. Children should be supervised to ensure they do not play with the appliance.

Do not allow any cables, furnishings, flammable materials or other items come in contact with any surface of the heater.

If installed in wet areas, the heater switches or controls must be located so that they cannot be touched by persons in the bath or shower.

The heater needs to be installed as per the installation instructions paying special attention to the minimum clearances. The heater needs to be mounted on a rigid bracket or fixing.

The heater must not be mounted immediately below or in front of a socket outlet.

In case of a heater fault or damaged supply lead, the appliance should be returned to the point of purchase for return to Thermofilm for repair.

Maintenance

The HEATSTRIP[®] Classic is made from durable materials, however regular care and maintenance of your heater will help prolong the life of the heater.

It is recommended that you hose down the heater and with a soft cloth gently wipe the surfaces of the heater with a mild detergent to remove the built up contaminants from the environment. Then rinse all detergent off the heater. All chemicals in the atmosphere including cigarette smoke, pollution etc. will tarnish the surface of the heater. In this case, additional cleaning and maintenance may be required. Carrying out the cleaning process at least every three months will reduce the amount of build up and keep the Heatstrip in good condition. If the heater is in a corrosive environment eg. salt spray, we recommend that you clean your heater with a light spray of fresh water every week. After cleaning, turn the heater on for 20 minutes to dry any water residue and prevent water staining. Before cleaning or inspection activity, the heater must be switched off and cooled down completely. Do not use any abrasive materials or products to clean the heater, this includes solvents, citrus based cleaners or other harsh cleaning products.

When handling the heater, ensure that your hands are clean or that you use clean gloves as grease or dirt can mark the surface of the heater.

Do not use high pressure water to clean heaters, light water spray only.



Warranty Terms & Conditions

The below Warranty Terms and Conditions apply for **New Zealand and Australia only**. For international warranty please refer to international warranty terms and conditions.

Thermofilm warrants to the original owner that HEATSTRIP[®] products will be free from defects in materials and workmanship for a period of 12 months from the date of purchase in accordance with the following warranty terms and conditions.

Provision of this warranty is subject to:

- The HEATSTRIP[®] products must be installed in accordance with the Installation Instructions and relevant electrical standards and codes.
- The HEATSTRIP[®] products must be maintained and cleaned according to instructions detailed in the Installation Manual.
- There is no warranty expressed or implied with regard to capacity requirements. The selection of the unit or units depends entirely upon the system design and capacities as determined by the purchaser.
- The customer has not repaired, opened or altered the product in any unauthorised manner.
- This warranty excludes damage to the product or components arising from circumstances outside the control of Thermofilm, including, but not limited to, where the product is not used for intended purpose; where the product has been rectified in any way; incorrect installation; incorrect power supply; damaged caused during delivery; misapplication, misuse, abuse, vandalism, lack of maintenance or accident.
- Thermofilm's obligations under this warranty are limited to repair or replacement at Thermofilm's factory of any components of the product which Thermofilm identifies to its satisfaction to be defective.
- Transportation charges involved in return of the product to the Thermofilm factory (or any other location authorised in writing by Thermofilm) is the sole responsibility of the customer.
- All products are inspected and tested before despatch and are at the risk of the purchaser after the shipment from the Thermofilm factory, if not delivered by Thermofilm to destination.
- No products or components will be supplied in advance of an examination of the faulty product or components by Thermofilm or an authorized representative of Thermofilm.
- Thermofilm does not participate in any site related costs or labour expenses incidental to replacement of parts, repairing, removing, installing, servicing, transportation or handling of parts to complete products, and assumes no liability on parts repaired or replaced without written authorisation. Thermofilm shall not be liable for any default or delay in performance of its warranty obligations caused by any circumstances beyond its control, including, but not limited to, judicial or government restrictions, strikes, fires, floods, abnormal weather conditions, delayed supply of components.

Should products be determined as damaged on arrival, immediately notify the transport company of the condition and have them noted on the freight documents. If damage is discovered after unpacking, demand immediate inspection by the transportation company and insist that a record of the damage is made on the freight documentation.

The customer warrants using the product in accordance with:

- Any instructions provided to it by Thermofilm from time to time.
- All government and local regulations, including but not limited to all relevant electrical, environmental laws and regulations governing the installation, storage, use, handling and maintenance of the goods.
- All necessary and appropriate precautions and safety measures relating to the installation, storage, use, handling and maintenance of goods.

Our goods come with guarantees that cannot be excluded under the Australian Consumer Law. You are entitled to a replacement or refund for a major failure and for compensation for any other reasonably foreseeable loss or damage. You are also entitled to have the goods repaired or replaced if the goods fail to be of acceptable quality and the failure does not amount to a major failure.

All warranty requests for repairs or replacements must be accompanied by a complete "Warranty Claim Form" available from Thermofilm, together with proof of purchase (and where possible, photos of the installation) and the heater returned to the place of purchase.

In the event of a warranty claim, the goods need to be returned to the distributor/retailer for repair/replacement. Contact
Thermofilm Australia Pty Ltd
8 Lakeview Drive, Scoresby, Victoria 3179, Australia
Telephone: (03) 9562 3455,
Email: sales@heatstrip.com.au