



cranmore 7

Operating & Installation Instructions

AUSTRALIA

CONTENTS

QUICK GUIDE	4
OPERATING INSTRUCTIONS	5
FUEL	5
LIGHTING	5
CONTROLLING THE FIRE	5
REFUELLING	6
ASH CLEARANCE	6
REDUCED BURNING	6
MAINTENANCE	6
BAFFLE AND FLUE CLEANING	7
FLUE SWEEPING	7
TROUBLE SHOOTING	7
IF YOU NEED FURTHER HELP	8
UNPACKING THE STOVE	9
HEALTH AND SAFETY PRECAUTIONS	9
SPECIFICATION	9
FLUE	9
HEARTH AND FIRE SURROUND	9
INSTALLATION INSTRUCTIONS	9
CONNECTIONS TO FLUES	10
PRE LIGHTING CHECK	10
COMMISSIONING	10
COOKING PLATE	10
CLEARANCES	12
STANDARD HEARTH DIMENSIONS	13
CORNER HEARTH DIMENSIONS	14
CRANMORE 7 DIMENSIONS	15
CRANMORE 7 PARTS LIST	16
FLUE CLEARANCES DIAGRAM	17
STANDARD DEFAULT TRIPLE SKIN FLUE KIT	18
INSULATED ROOM SEAL FLUE KIT	19
INSULATED ROOM SEAL FLUE KIT	20
INSULATED ROOM SEAL FLUE KIT	21
COMPLIANCE DATA	22
CHARNWOOD AUSTRALIA 10 YEAR GUARANTEE	23

QUICK GUIDE

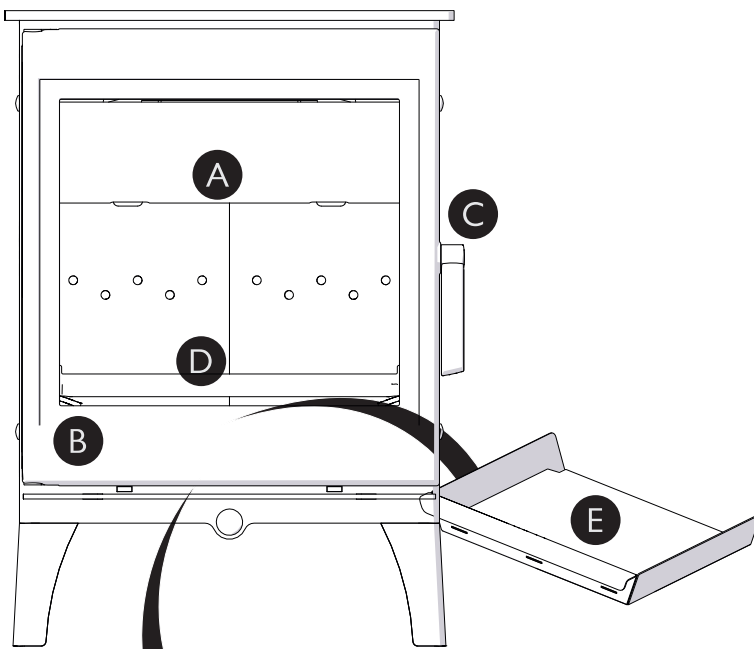

- A Baffle**
Improves efficiency of stove by slowing down flue gases
- B Door**
Keep closed when stove is in use
- C Door handle**
Pull to open
- D Optional fence**
Protects glass and prevents spillage
- E Sliding Ashpan**
For clean and easy ash removal

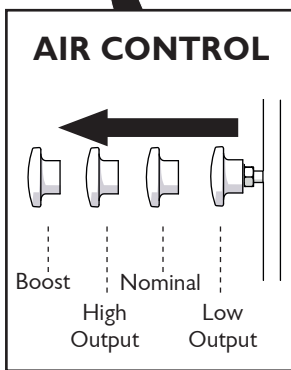

MAINTENANCE AND CLEANING

GLASS

Wipe with damp, lint free cloth. Any stubborn deposits on the glass may be removed with a proprietary stove glass cleaner or ceramic hob cleaner.

BAFFLE & UPPER BAFFLE

Take down once a month and clean. Sweep sooty deposits into fire

FLUE

Have flue swept annually. Flue can be swept through stove.

SERVICING

Stove should be serviced by a professional at least once a year.

LIGHTING AND CONTROLLING THE FIRE

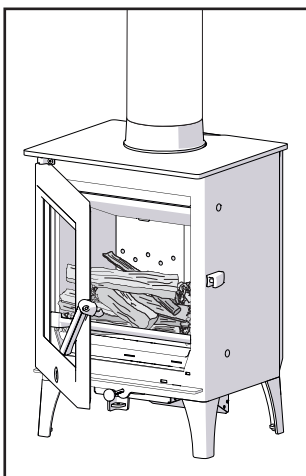

Add kindling and paper or firelighters. Keep air control fully out and door cracked open.

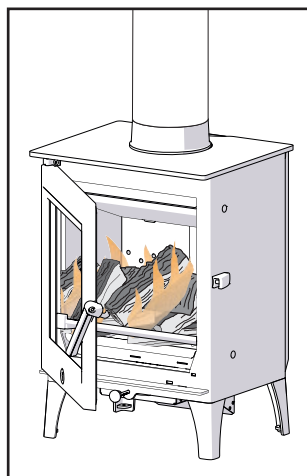

Once kindling is alight, add smaller logs. Keep air control fully out and close door.

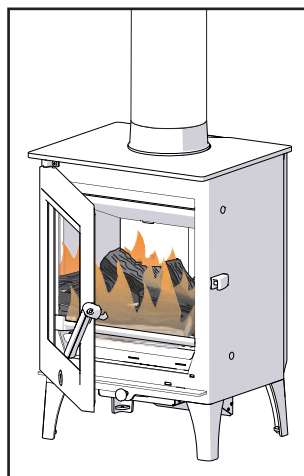

Add larger logs once fire is established. Air control can be reduced to minimum.

Suitable fuels for your

Charnwood:
Wood logs

Unsuitable fuels:

Petroleum coke
Liquid fuel
Household waste
Coal singles
Small nuts or coal dust
Wet or unseasoned wood
Smokeless mineral fuel



Congratulations on becoming the owner of a Charnwood Cranmore Stove. Your stove has been approved to burn wood logs if it is used in accordance with these instructions. It is very important that you read and understand these instructions before using the stove.

Before lighting the stove check with the installer that the work and checks described in the Installation Instructions have been carried out correctly and that the flue has been swept, is sound and free from any obstructions. The stove is not suitable for use in a shared flue system.

This stove will not produce significant smoke if well seasoned logs of less than 20% moisture content are burnt and these instructions are adhered to. Burning wet (>20% moisture content) wood and operating the stove in an irresponsible manner may produce smoke which is illegal in smoke controlled areas.

Remember that the stove will be hot and that it is made from hard materials – ensure that you have good balance before operating the fire. Always use the provided operating tool and gloves.

Do not use an aerosol spray on or near the stove when it is alight. There is a risk of explosion or flash ignition of the spray.

When using the stove in situations where children, aged and/or infirm persons are present a fireguard must be used to prevent accidental contact with the stove.

The stove is suitable for intermittent operation.

FUEL

This stove has been designated to burn wood. Only dry well seasoned wood should be burnt on this appliance as burning wet unseasoned wood will give rise to heavy tar deposits in the stove, on the glass and within the flue. Burning wet unseasoned wood will also result in considerably reduced outputs. The wood should be cut and split and then left to season in a well ventilated dry place for at least one year but preferably two years before use.

Approximate suitable log sizes are:

390mm(15in) long and 75mm (3in) diameter - Cranmore 7

Log moisture content of less than 20% is recommended.

PETROLEUM COKE IS NOT SUITABLE FOR USE ON THIS APPLIANCE. ITS USE WILL INVALIDATE THE GUARANTEE.

This stove is not designed to burn household waste.

LIGHTING

On initial lighting, the stove may smoke and give off an odour as the silicon paint with which the firebox is painted reacts to the heat. This is normal and will cease after a short time, but meanwhile the room should be kept well ventilated.

At first only light a small fire and burn it slowly for two hours to allow any residual moisture in the flue to evaporate.

Light the stove using dry kindling wood and paper or fire lighters. Put the paper, or fire lighters, and kindling in the firebox and cover with a few small dry logs. Open the air control fully (see Fig. 1) Light the paper or fire lighters. The door may be left cracked open for a few minutes to assist the combustion and heat up the firebox more quickly. When the kindling wood is well alight add a few more small logs, close the door but leave the air control fully open. When the flames are established around these logs, load the stove with the required fuel load. Maintain the air control at maximum at this stage. Once the fire is up to temperature the airwash system will begin to work, so allow the fire to become hot before adjusting the air control to the required setting. During the lighting period, do not leave the stove unattended. Do not leave the door open except as directed above to avoid excessive smoke.

When relighting the stove, leave the ash on the base, unless it is becoming too deep, in which case some of it may be removed.

CONTROLLING THE FIRE

The rate of burning and hence the output is controlled by the air control (see Fig.1)

Open the air control fully (boost position) when lighting or when rapid burning is required. It should not be left fully open for long periods as this can cause over-firing or excessive smoke production. For high output move the air control to the 'click position' or for low burning to the fully closed position.

When the fire is burning normally the air control gives enough airwash to keep the glass clean. However, it will not always be possible to keep the glass clean with the air control fully closed. For correct firing we recommend the use of a stove pipe thermometer which may be purchased from your supplier or from Charnwood.

The Charnwood Cranmore 7 is fitted with an air control stop. This stops the stove from burning too slowly.



Fig. 1 Stove controls

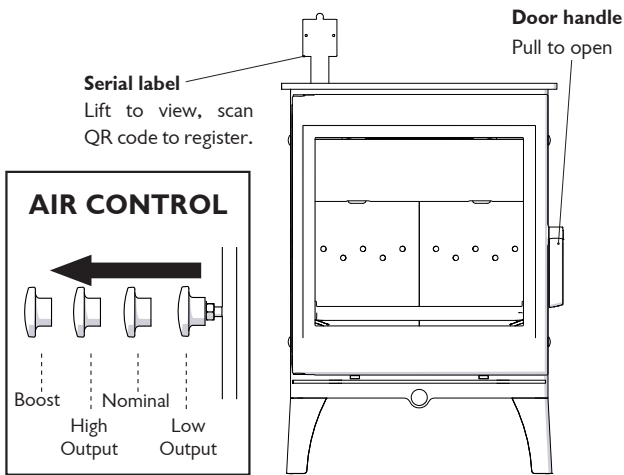

REFUELLING

Keep the firebox well filled but do not allow fuel to spill over the top of the fuel retainer.

Logs should be evenly distributed, filling the firebed to give the most pleasing flame pattern. The air control must be fully opened after refuelling until the flames are established above the fire. It is best to refuel on to a hot bed of embers. If at this point the fire starts to die, the door must be cracked open until the fire is revived. If the fire has started to die down before refuelling, then more kindling wood must be added, the air control opened fully and the door cracked open to re-establish the firebed before adding larger logs (see suitable log sizes in Fuel section). This will avoid excessive smoke emission.

Care should be taken, especially when burning wood, that fuel does not project over the fuel retainer or damage to the glass may be caused when the door is closed. It can also cause the glass to blacken up. Maximum filling height is such that logs cannot fall from the fire when the door is opened and does not come above the level of the air holes in back bricks.

Do not operate with the door open except as directed by the instructions as this can cause excessive smoke.

ASH CLEARANCE

Before removing ash ensure that it has cooled down. The ashpan slides out for easy ash removal.

To make ash removal easier there are ash carriers available. These may be purchased from your supplier or, in case of difficulty, from Charnwood.

REDUCED BURNING

For reduced burning the fire door must be closed.

When burning wood in areas that are not smoke controlled, load some large logs on the fire and allow to burn for half an hour before closing the air control (this will help to reduce tar deposits in the flue). Some experimentation may be necessary to find the setting most suitable for the type of fuel being used and the draw on the flue.

MAINTENANCE

Cleaning

The stove is finished with a high temperature paint which will withstand the temperatures encountered in normal use. This may be cleaned with a damp lint-free cloth when the stove is cold. Should re-painting become necessary, high temperature paints are available from your supplier or from stove shops.

Cleaning the Glass

Most deposits on the glass may be burnt off simply by running the fire at a fast rate for a few minutes. If it becomes necessary to clean the glass then open the door and allow it to cool. Clean the glass using a damp cloth and then wiping over with a dry cloth. Any stubborn deposits on the glass may be removed with a proprietary stove glass cleaner or ceramic hob cleaner. Do not use abrasive cleaners or pads as these can scratch the surface which will weaken the glass and cause premature failure

When Not in Use

If the fire is going to be out of use for a long period (for instance in the summer) then to prevent condensation, and hence corrosion, the air control should be left fully open and the fire door left ajar. It is also advisable to sweep the flue and clean out the fire. Spraying the inside of the door with a light oil, such as WD40, will also help to keep all internal parts working well. After long periods where the fire has been out of use, the flue and appliance flue should be cleaned before lighting.

Door Seals

For the fire to operate correctly it is important that the door seals are in good condition. Check that they do not become worn or frayed and replace them when necessary.

Servicing

It is recommended that the fire is serviced once a year to keep it in first class working order. After cleaning out the firebox thoroughly,



check that all internal parts are in good working order, replacing any parts that are beginning to show signs of wear. Check that the door seals are in good condition and that the doors seal correctly. A servicing guide is available on request. Repairs or modifications may only be carried out by the Manufacturer or their approved agents. Use only genuine Charnwood replacement parts.

BAFFLE AND FLUE CLEANING

It is important that the baffle and all the stove flue are kept clean in order to prevent potentially dangerous fume emission. They should be cleaned at least monthly, and more frequently if necessary. It is necessary to let the fire out to carry out these operations.

Slide the lower baffle forwards so that it clears the back bricks, then slide it either right or left so that the opposite side clears the retaining flange on the side brick and can be gently lowered. Any sooty deposits should then be swept from the baffle and into the fire.

On the Cranmore 7 there is an upper baffle plate that rests centrally on top of the air wash tubes and locates into the hook at the top of the front of the firebox. This should be removed and cleaned.

To return the lower baffle to its correct position- At an angle, insert the baffle so that it sits on top of either the right or left side of the retaining flange on the side bricks. Raise the opposite side of the baffle and slide so that the baffle is central and supported by both side bricks. Slide back so that the baffle rests neatly on the top of the back bricks.

FLUE SWEEPING

When installing your Charnwood into an existing brick flue that has previously served as an open fire, it is possible that the higher flue gas temperature from a stove may loosen soot deposits with the consequent risk of flue blockage. It is therefore recommended that the flue be swept a second time within a month of regular use after installation.

Your Charnwood flue should be swept at least twice a year. Where the top outlet or vertical rear flue connector is used it will generally be possible to sweep the flue through the appliance.

First remove the upper and lower baffles. Then sweep the flue ensuring that soot is removed from all horizontal surfaces after sweeping.

In situations where it is not possible to sweep through the appliance the installer will have provided alternative means, such as a flue

access door.

After clearing any soot from within the stove, replace the baffle (see Fig. 2).

It is important to use the correct flue brush for the flue size, different types of sweep's brushes are available to suit different flue.

For prefabricated insulated flues the manufacturers instructions with regard to sweeping should be consulted.

Fig.2 Baffle Location

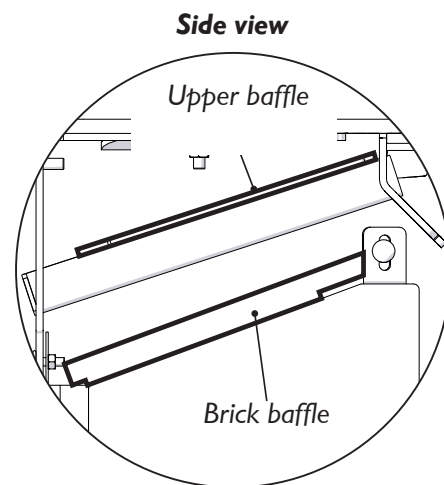

TROUBLE SHOOTING

Fire Will Not Burn

Check that:

- the air inlet is not obstructed in any way,
- flues and flue are clear,
- a suitable fuel is being used,
- there is an adequate air supply into the room,
- If an extractor fan is fitted, that it is not causing lack of flue draft when operating.
- there is sufficient draw in the flue. Once the flue is warm a draught reading of at least 1.25 mm (0.05 in.) water gauge (12Pa) should be obtained.

Blackening of Door Glass

Differences in flue draughts mean that the best settings of the air controls will vary for different installations. A certain amount of experimentation may be required, however the following points should be noted and with a little care should enable the glass to be kept clean in most situations:



- a) Wet or unseasoned wood, or logs overhanging the front fence will cause the glass to blacken.
- b) The airwash relies on a supply of heated air to keep the glass clean, therefore, when lighting the stove allow the firebed to become well established before closing the air control. This may also be necessary when re-fuelling the stove.
- c) When re-fuelling keep the fuel as far back from the front fence as possible, do not try to fit too much fuel into the firebox
- d) Do not completely close the air control.

It is always more difficult to keep the glass clean when running the stove very slowly for long periods.

If blackening of the glass still occurs check that all flue connections and the blanking plate are well sealed. It is also important that the flue draw is sufficient and that it is not affected by down-draught. When the flue is warm a draught reading of at least 1.25 mm (0.05 in.) water gauge (12Pa) should be obtained. Some blackening of the glass may occur below the level of the fuel retainer. This will not obscure the view of the fire or affect its performance.

Fume Emission

Warning Note: Properly installed and operated this appliance will not emit fumes. Occasional fumes from de-ashing and re-fuelling may occur. Persistent fume emission is potentially dangerous and must not be tolerated. If fume emission does persist, then the following immediate actions should be taken:

- a) **Open doors and windows to ventilate the room and then leave the premises.**
- b) **Let the fire out and safely dispose of the fuel from the appliance.**
- c) **Check for flue or flue blockage, and clean if required.**
- d) **Do not attempt to re-light the fire until cause of fuming has been identified, if necessary seek professional advice.**

The most common cause of fume emission is a flue blockage. For your own safety the flue must be kept clean

Fire blazing out of control

Check that:

- a) The door is tightly closed.
- b) The air control slider is fully closed.
- c) A suitable fuel is being used.
- d) Door seals and air slide are intact.

Flue Fires

If the flue is thoroughly and regularly swept, flue fires should not occur. However, if a flue fire does occur close the air control, and tightly close the door of the appliance. This should cause the flue fire to go out in which case the controls should be kept closed until the stove has gone out. The flue should then be cleaned. If the flue fire does not go out when the above action is taken then the fire brigade should be called immediately. After a flue fire the chimney should be carefully examined for any damage. Expert advice should be sought if necessary

IF YOU NEED FURTHER HELP

If you need further help with your Charnwood then your Installer will be able to provide the answers to most questions. Your Local Charnwood Dealer has a great deal of experience and will also be able to provide helpful advice. Further help is available from Pivot Stove & Heating who will be pleased to give advice, if necessary.



UNPACKING THE STOVE

The stove arrives bolted and strapped to its pallet. There must be adequate facilities for unloading and manoeuvring into position. The wrapping is first removed, then the stove released from the pallet by removing 4 pallet bolts using a 10mm spanner. The pallet brackets can now be removed from the stove by tilting it and using a 13mm spanner to remove the bolts. The bolts should be refitted and used for levelling the stove. The pallet is intended to be cut up and used for kindling fuel.

HEALTH AND SAFETY PRECAUTIONS

Please take care when installing the stove.

Ideally there should not be an extractor fan fitted in the same room as the appliance. If this situation is unavoidable then specialist advice should be taken to ensure that the extractor fan does not cause the appliance to emit fumes into the room. The external air kit will help with this in some situations. Alternatively, an additional air supply correctly positioned may be necessary. It is essential to carry out a spillage test to ensure that the appliance can operate safely when the extractor fan is operating.

There must be an adequate air supply into the room in which the appliance is installed to provide combustion air. The combustion air supply must be via a permanently open vent. The requirement for minimum free area is partly dependent on the design air permeability of the house. In older properties the air permeability will be above $5.0\text{m}^3/(\text{h}\cdot\text{m}^2)$, but in some modern properties it may be less. The vent must be positioned such that it is not liable to blockage. Minimum areas are given in the following table:

AIR PERMEABILITY $\text{m}^3/(\text{h}\cdot\text{m}^2)$	MINIMUM VENT AREA $\text{cm}^2(\text{in}^2)$
	Cranmore 7
>5.0	11 (1.76)
<5.0	38.5 (6.0)

A fixed ducted air supply may be used as an alternative to the traditional method of using a permanent open vent into a room to supply air for combustion.

External air supply kits are available please contact Charnwood for more information. Instruction sheet ref: TIS 120

It is recommended that a carbon monoxide alarm is installed in the same room as the appliance, in accordance with the alarm manufacturer's instructions.

SPECIFICATION

SPECIFICATION	Cranmore 7
Fuel	Wood logs
Maximum average heat output burning hardwood:	5kW
Overall average efficiency burning hardwood:	69%
Particulate emissions factor:	1.4g/kg

FLUE

In order for the appliance to perform satisfactorily the flue must give sufficient draw when warm (minimum of 12pa/0.05" wg). The height of the flue must comply with local building regulation requirements. The internal dimensions of the chimney **MUST NOT BE LESS THAN 150mm (6") - Cranmore 7.**

The listed flue's construction and installation must comply with the requirements of AS/NZS2918:2018 and must also meet local building codes. The flue must be suitable for burning solid fuel, lined in good condition and at least 4.6m in height from the base of the appliance. The flue and all its component's must be installed according to the manufacturer's instructions. The flue exit requirements of AS/NZS2918:2018 are 1000mm above the roof and 600mm above any projection within 3000mm, see flue clearances diagram (page 20). This stove is not suitable for use in a shared flue system.

It is important that there is sufficient draw in the flue and that the flue does not suffer from down-draught. When the flue is warm the draw should be not less than 1.25mm (0.05") water gauge (12 Pa). If in doubt about the chimney seek expert advice.

HEARTH AND FIRE SURROUND

The stove must stand on a fireproof hearth and must not be situated closer than the minimum distance from combustible materials to the sides or rear above hearth level unless adequately fireproofed in accordance with local building regulations. If installed on a combustible floor, floor protection must be provided in the form of a non-combustible material to the minimum specifications described in the 'minimum distances to combustibles' section (pages 11 & 12) When the fire door is open, it extends beyond the flat front of the stove by 497mm.

If in doubt as to the positioning of the stove, expert advice should be



sought either from the supplier or the local building inspector. The fireplace must allow good circulation of air around the appliance to ensure that maximum heat is transferred to the room and also to prevent the fireplace from overheating. A gap of 150mm (6") each side and 300mm (12") above the appliance should give sufficient air circulation. If a wooden mantelpiece or beam is used in the fireplace it should be a minimum of 460mm (18"), and preferably 600mm (24") from the appliance. In some situations it may be necessary to shield the beam or mantelpiece to protect it.

In order for the fire to operate correctly the rear air inlet must not be obstructed.

The appliance should be installed on a floor with adequate load-bearing capacity. If an existing construction does not meet this requirement then please take suitable measures to achieve this. (e.g. load distributing plate.)

CONNECTIONS TO FLUES

The Cranmore 7 must be connected to the flue using flue pipe of 150mm (6") diameter : and is tested for both Air Cooled triple Skin Flue Kits & Room Seal Insulated flue Kits that have been tested to AS/NZS2918:2018

Horizontal lengths of flue must be kept to a minimum and should not be more in length than the flue diameter.

The stove comes with the blanking plate (fig. 9) fitted to the rear flue outlet. The seal for the top outlet is a 155mm dia ring of rope seal. The seal for the rear outlet is a length of adhesive backed fibre webbing supplied with instructions ref: TIS093. This is applied to the flue collar or the Vertical Rear Flue adapter for rear outlet installations.

PRE LIGHTING CHECK

Ensure that the baffle and upper baffle is fitted in the roof of the appliance. For location and positioning see Fig. 2.

Check that the front fence is fitted correctly and that the door closes properly.

COMMISSIONING

On completion of the installation allow a suitable period of time for the fire cement and mortar to dry out before lighting the fire. Make a layer of ash or sand on the base of the stove before lighting. Check to ensure that smoke and fumes are taken from the appliance up the flue and emitted safely. Also check all joints and seals. On completion of the installation and commissioning please leave the operating instructions with the customer and advise them on the use of the appliance.

Fig. 9. Flue Blanking Plate.

COOKING PLATE

A Cooking plate attachment is available for all Cranmore models:

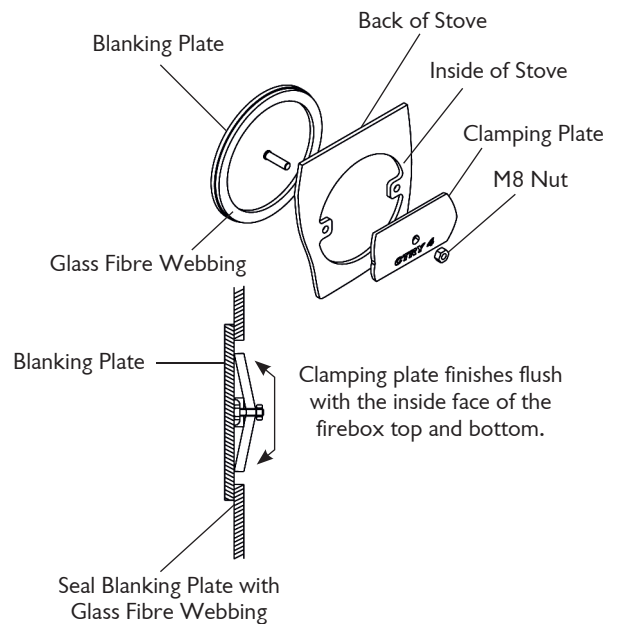

010/BP150S - 6 inch kit used on the Cranmore 7

The kit comprises of a cooking plate and four trivets and can only be fitted to the stove if a rear flue connection is made. For more information see sheet REF. TIS136.





PARALLEL POSITION

CORNER POSITION

COMBUSTIBLE WALLS

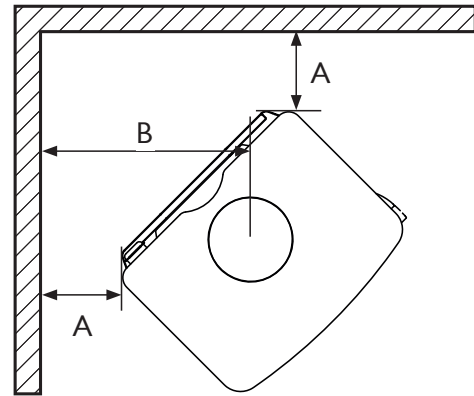
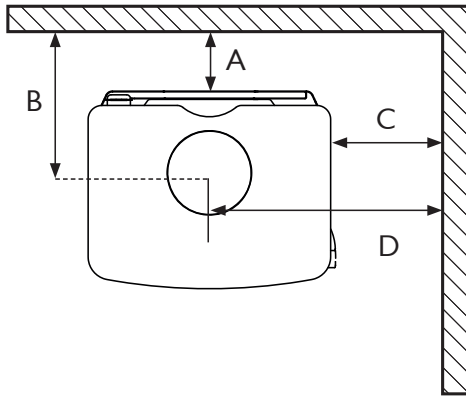

CRANMORE 7

Standard Clearance

A	100mm
B	276mm
C	425mm
D	688mm

Corner Clearance

A	250mm
B	526mm

STANDARD HEARTH DIMENSIONS



DEFAULT HEARTH

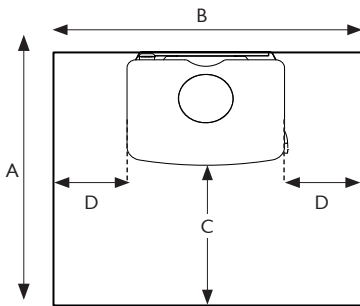

TO WALL

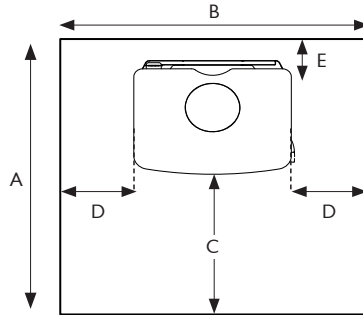

VERTICAL REAR FLUE ADAPTOR

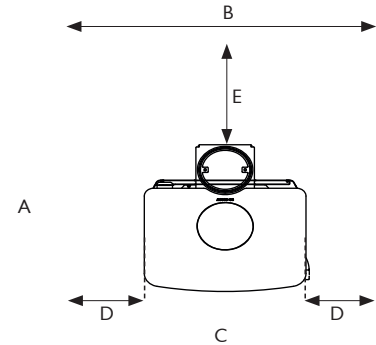

CRANMORE 7

MIN. DIMENSIONS DEFAULT HEARTH

A	915mm
B	820mm
C	490mm
D	250mm

MIN. DIMENSIONS TO WALL

A	1015mm
B	820mm
C	490mm
D	250mm
E	100mm

VERTICAL REAR FLUE ADAPTOR

MIN. DIMENSIONS TO WALL

A	1512mm
B	820mm
C	490mm
D	250mm
E	458mm

NON-COMBUSTIBLE MATERIAL

Minimum thickness: 6mm

Minimum thermal resistivity: 0.1m²K/W - Cranmore 7

Installed in accordance with AS/NZS 2918:2018 3.3.2

CORNER HEARTH DIMENSIONS



Minimum dimensions to wall

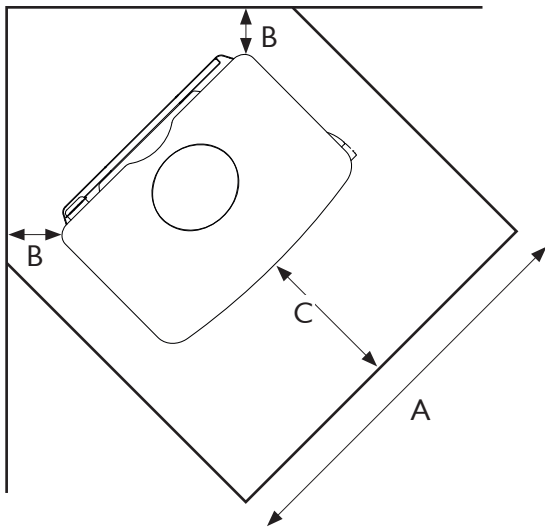

VERTICAL REAR FLUE ADAPTOR

Minimum dimensions to wall

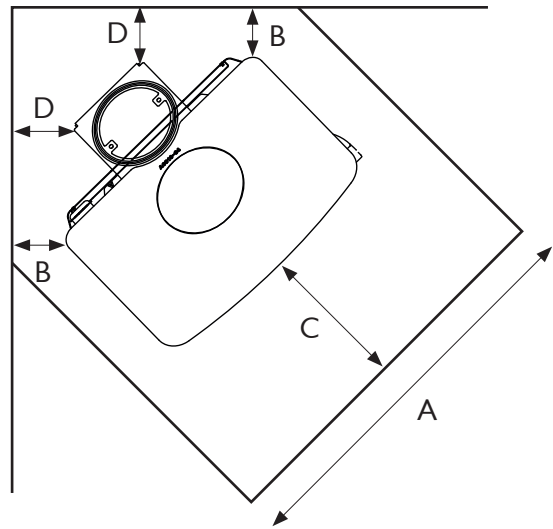

CRANMORE 7

CORNER HEARTH

A	820mm
B	526mm
C	490mm

WITH VERTICAL REAR FLUE ADAPTOR

A	820mm
B	526mm
C	490mm
D	458mm

NON-COMBUSTIBLE MATERIAL

Minimum thickness: 6mm

Minimum thermal resistivity: 0.1m²K/W - Cranmore 7

Installed in accordance with AS/NZS 2918:2018 3.3.2

CRANMORE 7 DIMENSIONS

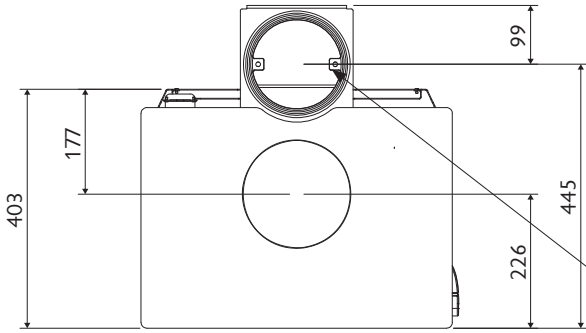

PLAN VIEW

VERTICAL REAR FLUE ADAPTOR

To suit 150mm
(6") flue pipe

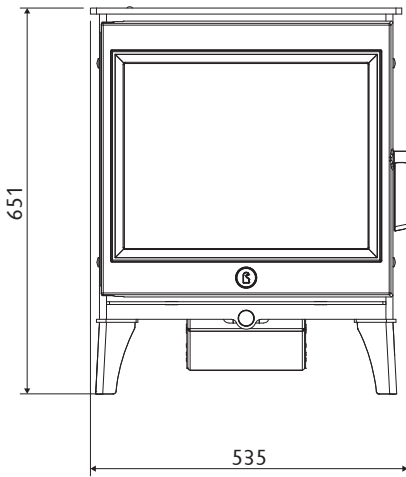

FRONT

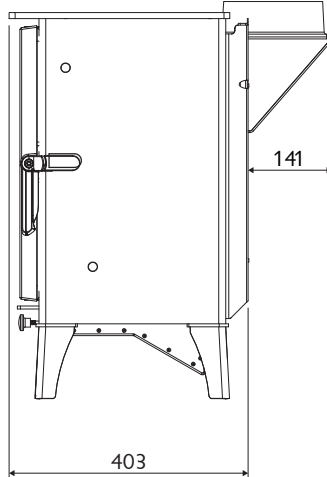

SIDE

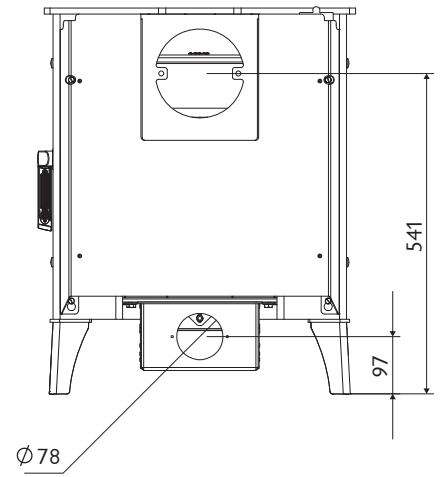

REAR

CRANMORE 7 PARTS LIST



Issue A

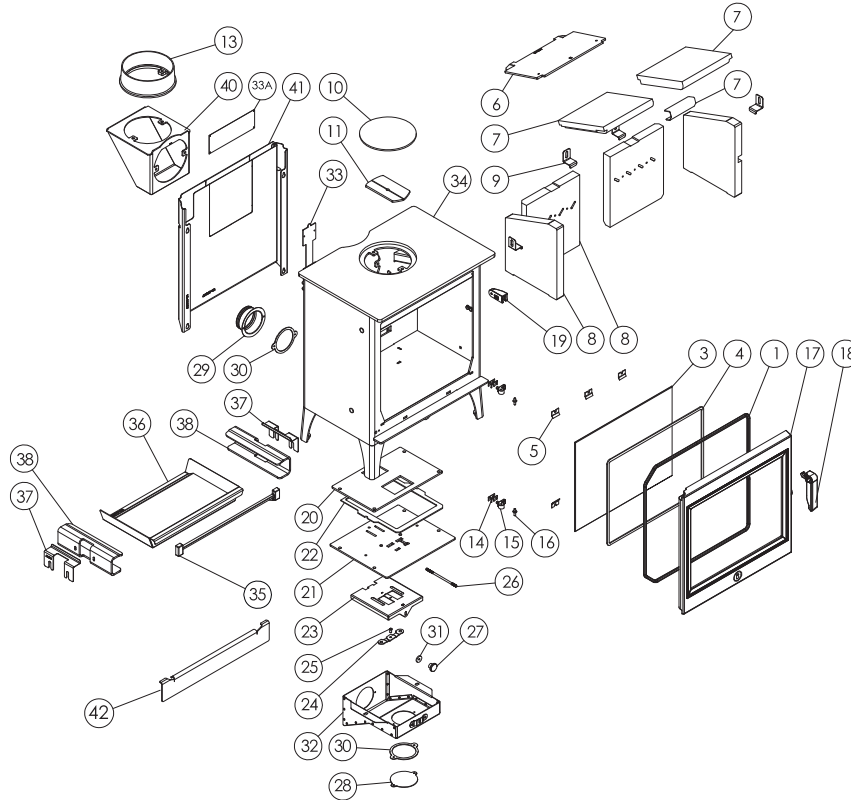

Item	Part No.	Description	Item	Part No.	Description
1	008/AC035	Door Seal (Inc Adhesive)	25	008/ES36/01	Brass Ball Catch
1	008/AC035	Door Seal (Inc Adhesive)	26	004/AA084	Control Rod
2*	008/FW29	Door Seal Adhesive	26	004/AA084	Control Rod
3	006/AC018	Glass (Inc Seal)	27	008/AY37	Air Control Handle
3	006/AC018	Glass (Inc Seal)	27	008/AY37	Air Control Handle
4	008/EW45	Glass Seal	28	004/CR064	Cover Plate
4	008/EW45	Glass Seal	28	004/CR064	Cover Plate
5	004/KV23	Glass Retainer	29	010/CR048/S	Air Inlet Spigot
5	004/KV23	Glass Retainer	29	010/CR048/S	Air Inlet Spigot
6	010/AC042	Upper Throat Plate	30	008/CR063	Air Inlet Gasket
6	010/AC042	Upper Throat Plate	30	008/CR063	Air Inlet Gasket
7	011/AC031S	Set of Throat Plate Bricks Inc. Bracket	31	008/BR052	Felt Washer
7	011/AC031S	Set of Throat Plate Bricks Inc. Bracket	31	008/BR052	Felt Washer
8	011/AC028S	Set of Fire Bricks	32	004/LC040	Airbox Cover
8	011/AC028S	Set of Fire Bricks	32	004/LC040	Airbox Cover
9	004/XV30	Brick Bracket	33	012/LDA011	Serial No. Label
9	004/XV30	Brick Bracket	33	012/LDA011	Serial No. Label
10	012/TW09	Blanking Plate	33a	012/LDA0180	Compliance Label
10	012/TW09	Blanking Plate	34	001/LD010	Firebox
11	010/AY51	Clamping Plate	34	001/LD010	Firebox
11	010/AY51	Clamping Plate	35	002/AC008	Front Fence
12*	008/NV38	Flue Fixing Rope Seal	35	002/AC008	Front Fence
13#	002/CH12B	Flue Collar	36	004/AC017	Ashpan
14	004/BR021	Hinge Shim	36	004/AC017	Ashpan
14	004/BR021	Hinge Shim	37	004/AB044	Brick Retainer
15	002/AC020	Hinge	37	004/AB044	Brick Retainer
15	002/AC020	Hinge	38	010/AB016	Side Plate
16	008/ST073/2	Hinge Pin Set	38	010/AB016	Side Plate
16	008/ST073/2	Hinge Pin Set	39*	010/EW51	Ash Carrier (Optional Extra)
17#	003/LD001A	Door Assembly	40#	010/TW33	Vert Rear Flue Adaptor (Opt'l Extra)
18#	003/AB012A	Door Handle	41#	010/LD080	Heat Shield (Optional Extra)
19#	003/AB055A	Latch Receiver	42	010/AC006	Ash Retainer (Optional Extra)
20	008/AB110	Air Control Gasket	42	010/AC006	Ash Retainer (Optional Extra)
20	008/AB110	Air Control Gasket	008/NV38	Flue Fixing Rope Seal	
21	010/LD130	Air Control Plate	002/CH12B	Flue Collar	
21	010/LD130	Air Control Plate	003/LD001A	Door Assembly	
22	008/LC045	Air Control Cover Gasket	003/AB012A	Door Handle	
22	008/LC045	Air Control Cover Gasket	003/AB055A	Latch Receiver	
23	004/AC115	Slider	012/LDA0180	Compliance Label	
23	004/AC115	Slider	010/EW51	Ash Carrier (Optional Extra)	
24	004/BR015	Clicker Retainer Plate	010/TW33	Vert Rear Flue Adaptor (Opt'l Extra)	
24	004/BR015	Clicker Retainer Plate	008/FW29	Door Seal Adhesive	
25	008/ES36/01	Brass Ball Catch	010/LD080	Heat Shield (Optional Extra)	

*These items are not shown on the drawing.
Please specify colour when ordering.

To obtain spare parts please contact your local stockist giving Model, Part and Description. In case of difficulty contact the manufacturer at the address shown. This drawing is for identification purposes only.

FLUE CLEARANCES DIAGRAM



Summary of minimum height of flue system exit requirements from AS/NZS 2918:2018

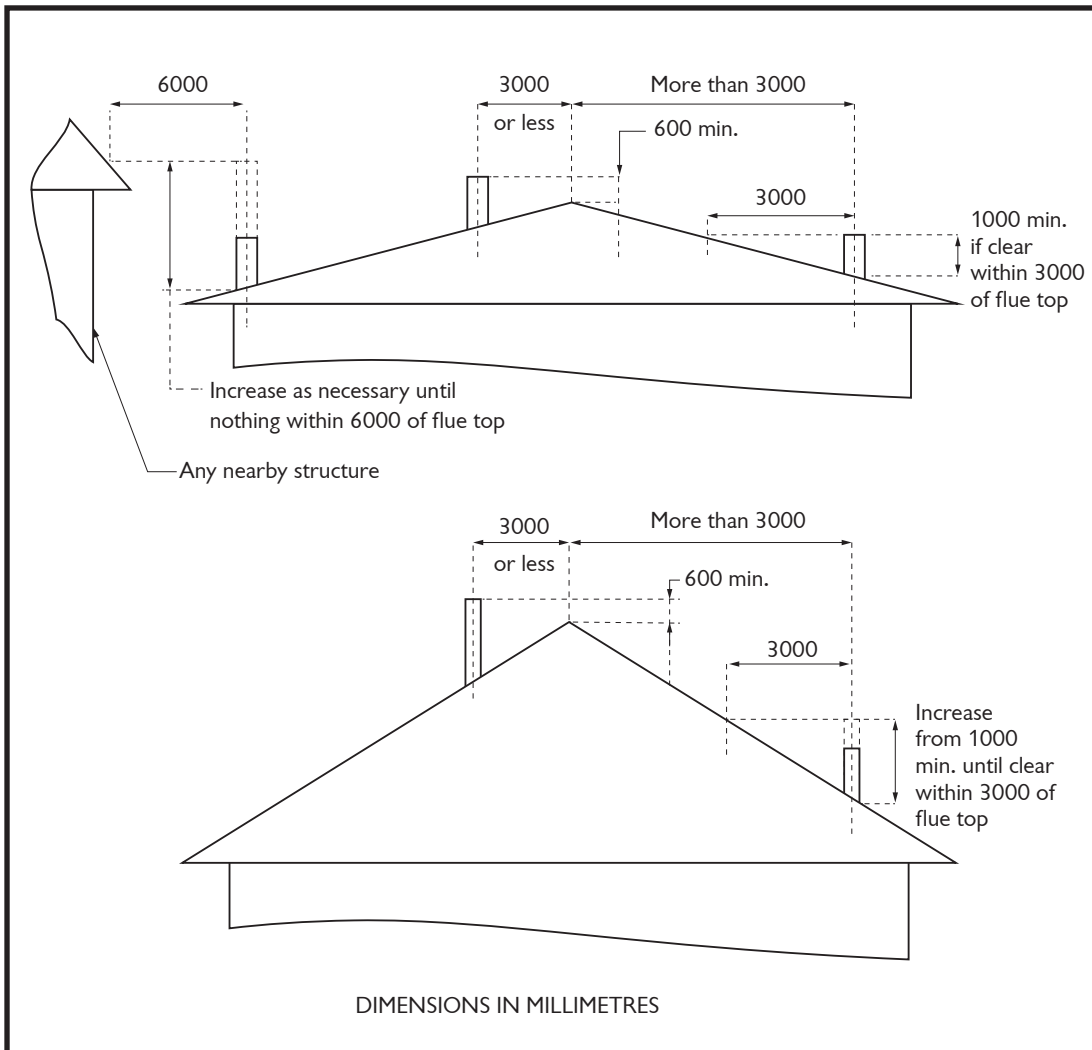

STANDARD DEFAULT TRIPLE SKIN FLUE KIT

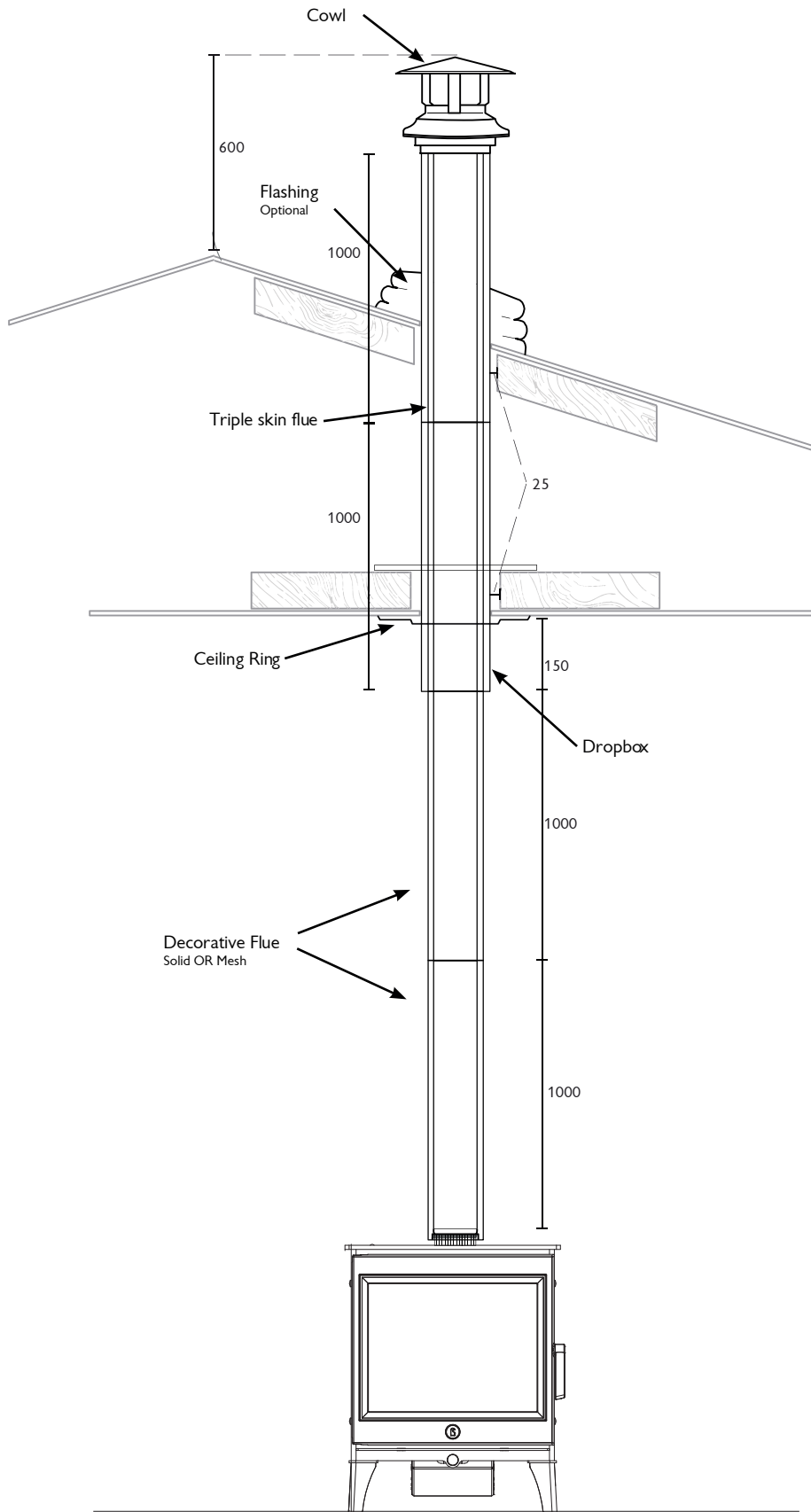

INSULATED ROOM SEAL FLUE KIT



STANDARD FLUE KIT

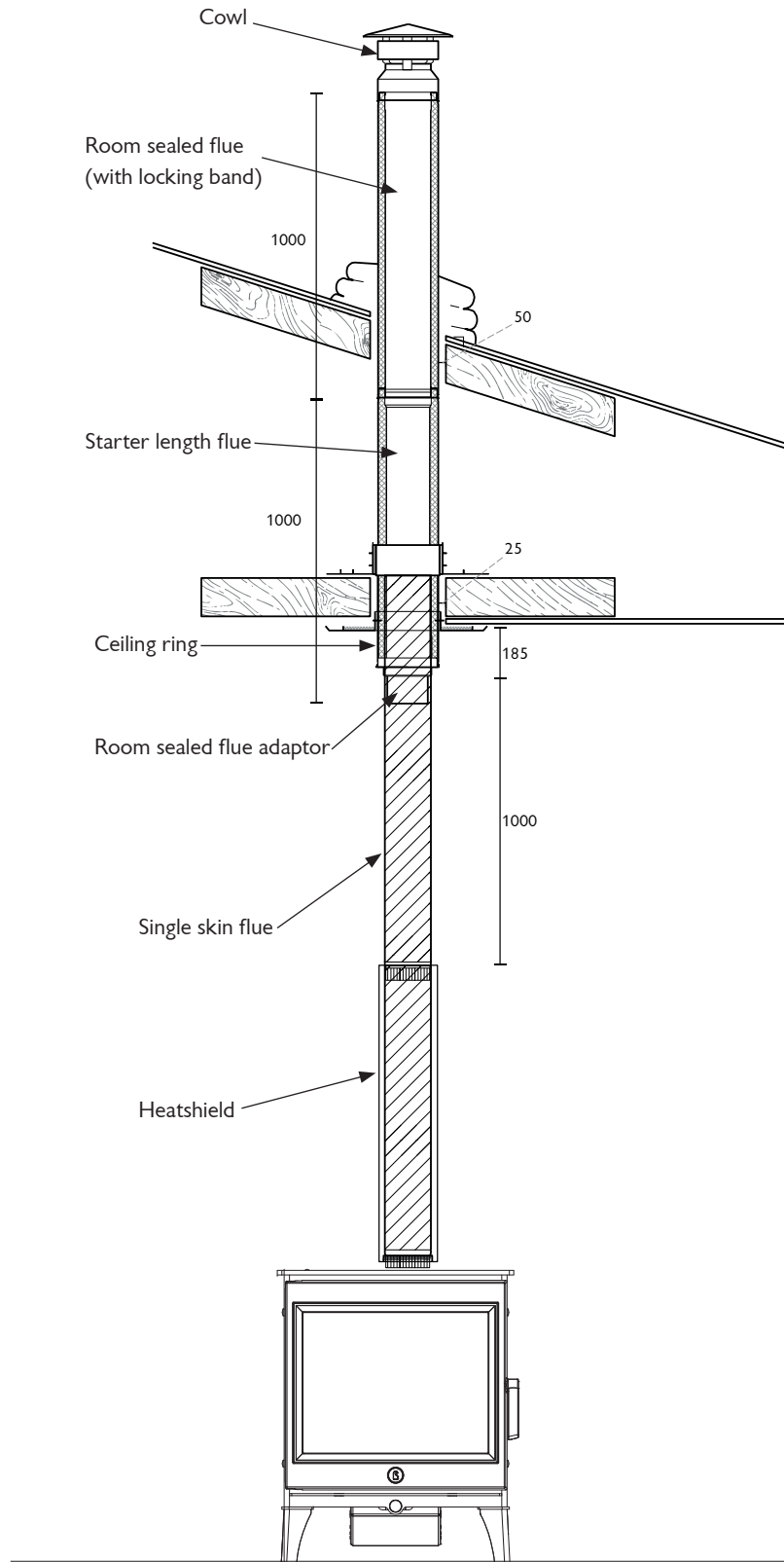

INSULATED ROOM SEAL FLUE KIT



FULLY SEALED FLUE KIT

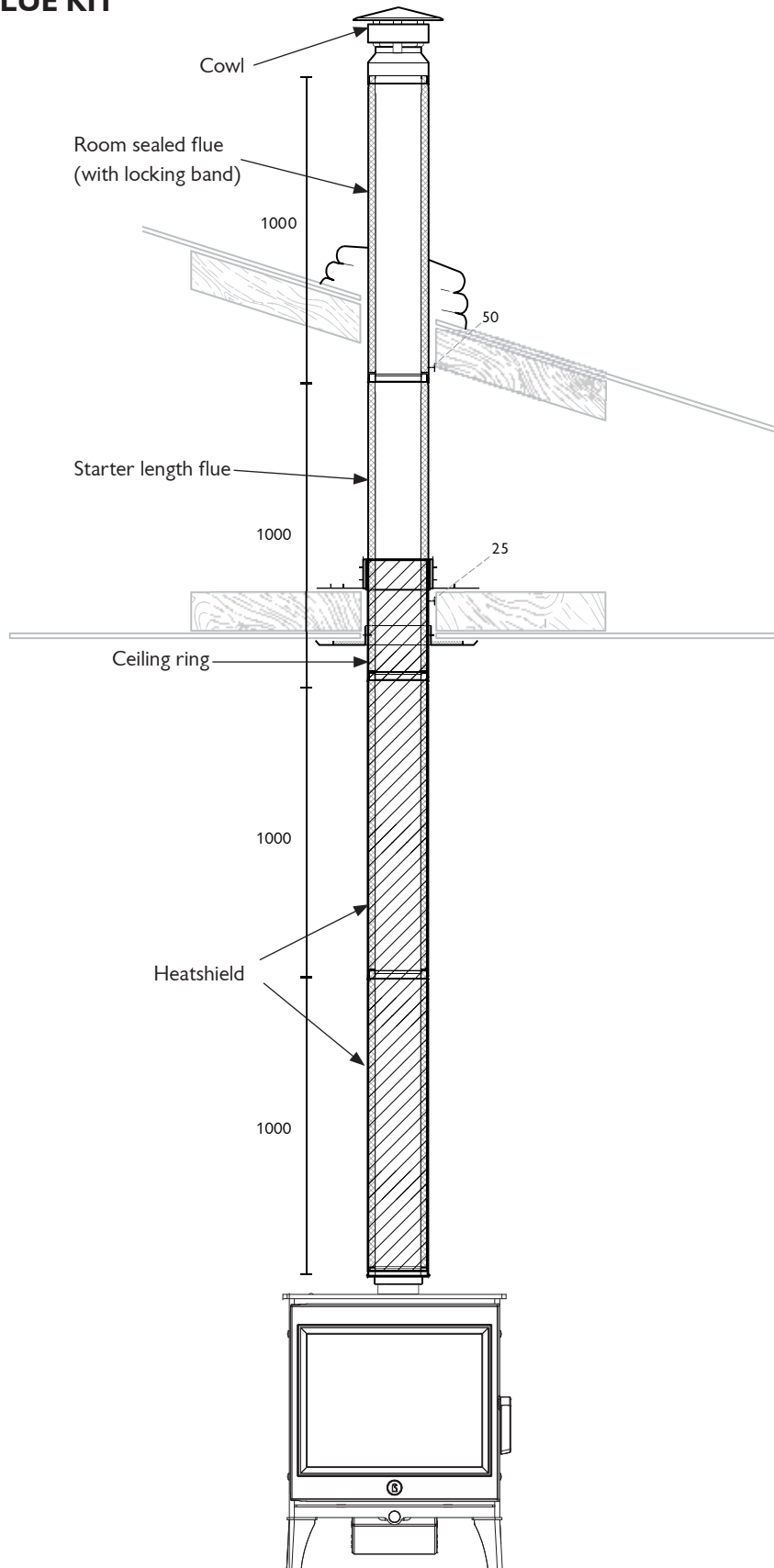

INSULATED ROOM SEAL FLUE KIT



REAR FLUE KIT

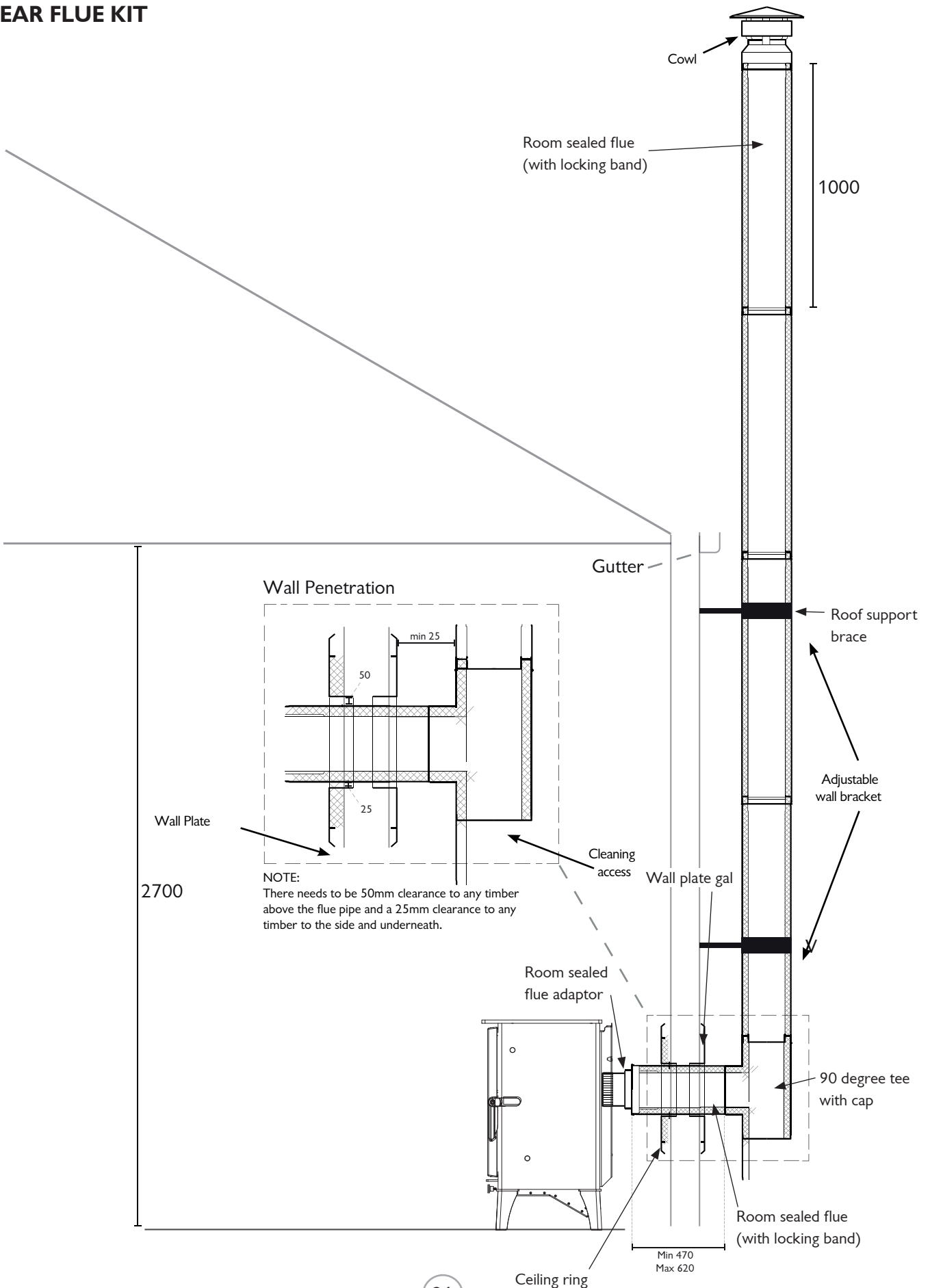

COMPLIANCE DATA



CRANMORE 7 COMPLIANCE DATA



CHARNWOOD
NEWPORT, IW
PO30 5WS, UK
WWW.CHARNWOOD.COM

DISTRIBUTED BY:
PIVOT STOVE & HEATING CO
120 VICTORIA ST,
NORTH GEELONG VIC 3215,
AUSTRALIA

ONLY USE RECOMMENDED FUELS.

This wood heater needs periodic inspection and repair for proper operation. Consult the operating & installation manual for minimum clearance distances from combustibles. No catalytic combustor. Follow the users instructions.

TESTED BY:	ASFT
TEST REPORT NO:	ASFT20104-1
TESTED TO:	AS/NZS 4012/4013 (2014)
DATE:	24/02/2022

MODEL:	Cranmore 7
MODEL CODE:	LDA
TYPE:	Freestanding

MAXIMUM AVERAGE HEAT OUTPUT
BURNING HARDWOOD: **5kW**

OVERALL AVERAGE EFFICIENCY
BURNING HARDWOOD: **69%**

PARTICULATE EMISSIONS FACTOR: **1.4g/kg**

Compliance plate riveted onto rear heatshield

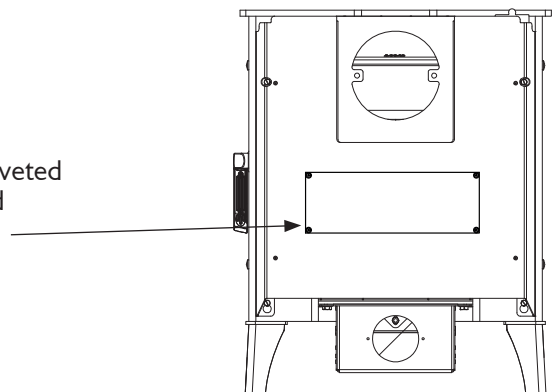

CHARNWOOD AUSTRALIA 10 YEAR GUARANTEE



To register your 10 Year Stove Guarantee please visit or scan QR:

www.charnwood.com/my-stove/guarantees/

and enter the following code: CGG-AUS

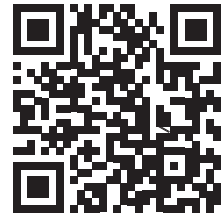

TERMS AND CONDITIONS

10 Year Warranty: The firebox of your Charnwood Stove is guaranteed against material and manufacturing defect for a period of 10 years

1 Year Warranty: The consumable items such as bricks, rope seal and associated parts are guaranteed for a period of 1 year.

- The guarantee registration form must be completed online and submitted within 14 days of purchase to enable the guarantee to be activated.
- The following conditions apply:
- If any part fails due to manufacturing or material defect within the guarantee period Charnwood will, free of charge, either repair or replace the part at their discretion. The decision of Charnwood is final.
- This guarantee is for parts only.
- Charnwood will not be liable for any consequential loss or incidental loss, damage or injury however caused.
- This guarantee will become void if the appliance: is not installed in accordance with the installation instructions; is not regularly serviced in accordance with the installation instructions; is subject to misuse or neglect, including the use of non-recommended fuel; or if repairs or modifications have been carried out by anyone other than Charnwood or their official representatives.
- All claims on this guarantee must be made through the supplier of the appliance and must be accompanied by proof of purchase.
- Nothing in this guarantee shall affect your statutory rights.

EXCLUSIONS AND LIMITATIONS

This Guarantee does not cover the following:

- Charnwood will not be liable for any consequential loss or incidental loss, damage or injury however caused.
- This guarantee will become void if the appliance is not installed by a suitably qualified and is not installed in accordance with the AS.NZS 2918
- This guarantee will become void if the appliance is not installed in accordance with the installation instructions and is not regularly serviced, in accordance with the installation instructions.
- If the product is subject to misuse or neglect, including the use of non-recommended fuels.
- If repairs or modifications have been carried out by anyone other than Charnwood or their authorised representatives.
- Damage caused by over-firing of the stove. Please refer to our operating instructions for further details.
- Damage caused by storing or using the product in a damp environment. Corrosion caused by condensation, damp or water ingress into the flue, chimney or the surrounding of the stove.
- Defects or faults caused by local conditions such as draught problems and chimney defects.
- The paint finish will require touching up or repainting from time to time. Maintaining the finish is normal practice and is not covered by the guarantee.

your premier dealer

charnwood BISHOPS WAY, NEWPORT, ISLE OF WIGHT PO30 5WS, UNITED KINGDOM
TEL. +44 (0) 1983 537777 • FAX. +44 (0) 1983 537788 • WWW.CHARNWOOD.COM

A Division of A.J.Wells & Sons Limited Registered in England No. 03809371