

**Notes:**  
 Connection of approved flue ducting required. Check local codes and regulations.  
 Oven fully finished in one piece - Approx 320kg

For Installation Requirements Contact Zesti Commercial Direct Consult Operation Manual For Details

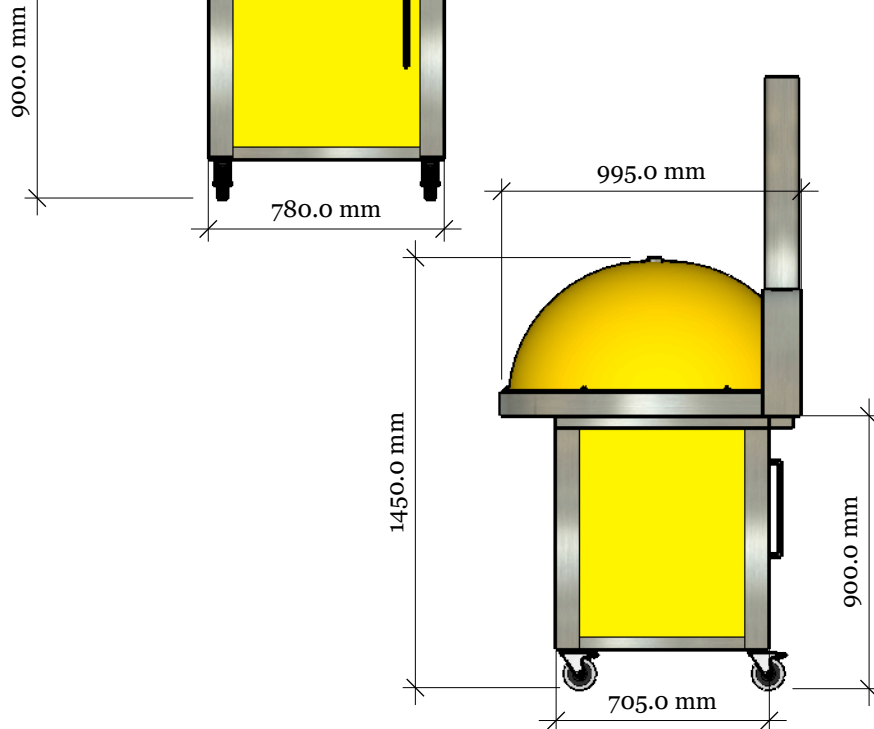

Custom Poured Refractory Dome Fully Insulated To 1260.C

Colour Coded Fully Insulated

Side Prep Wings

Custom Fabricated Front Arch Fully Welded And Polished To A Grain

Fully Inclosed Trolley Cabinet With Door Fitted With Self Closing Hinges

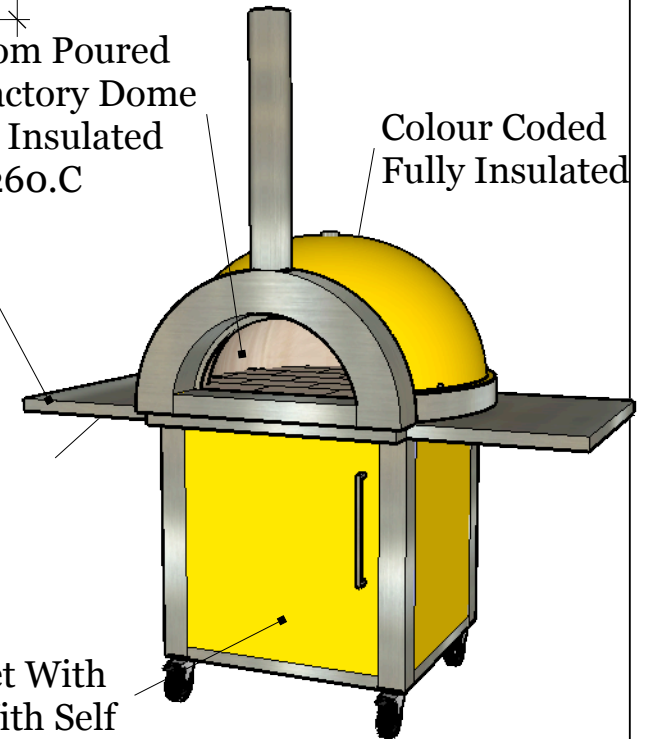

Zesti Ovens PTY LTD  
 Unit 3/43 Westchester Road  
 Malaga, Perth, Western Australia  
 6090  
 Phone: +61 (8) 92093103  
 zestiovens@iprimus.com.au  
 ABN 36169842623

**ZRW REFRACTORY OVEN SET  
 ON FULLY INCLOSED TROLLEY  
 WITH SIDE PREP WINGS**

All Designs Remain The Property Of Zesti Ovens PTY LTD

Drawn By	Theo	Checked	Scale	Date
Version:	V1	Hi-Spec Custom Built Insulated Refractory Oven Set On Fully Inclosed Trolley With Side Prep Wings ZRW Model		28/8/20
				<b>A4</b>
<b>ZRW-Tfc-PrepW2-1100 DETAILS</b>				